

# **TURBINE FUEL PUMP MAINTENANCE AND OVERHAUL MANUAL**

**P/N: FC5001**

## **500F Series Fuel Pumps**

### **Model Numbers:**

**500F-0001  
500F-0002  
500F-0004**

THIS PAGE INTENTIONALLY LEFT BLANK

**Table of Contents**

Record of Revisions ..... ix

Service Publication List ..... xi

Introduction..... 1

Airworthiness Limitations..... A-1

    A.1 Airworthiness Limitations Statement..... A-1

    A.2 Life Limits ..... A-1

Chapter 1 - Description and Operation ..... 1-1

    1.1 Description ..... 1-1

    1.2 Operation ..... 1-1

    1.3 Parts Identification ..... 1-5

    1.4 Specification for Fuel Pump Operation..... 1-7

    1.5 Use of Non-HET Certified Parts..... 1-7

Chapter 2 - Troubleshooting ..... 2-1

    2.1 General ..... 2-1

Chapter 3 - Disassembly ..... 3-1

    3.1 General ..... 3-1

    3.2 Disassembly of the 500F Series Fuel Pump ..... 3-3

Chapter 4 - Cleaning ..... 4-1

    4.1 General ..... 4-1

    4.2 Specific Cleaning Instructions..... 4-1

Chapter 5 - Checks ..... 5-1

    5.1 General ..... 5-1

    5.2 Inspection Interval Requirements ..... 5-1

    5.3 Inspection Requirements - 500F Series Fuel Pumps..... 5-1

    5.4 Replacement Requirements ..... 5-2

    5.5 Repair..... 5-2

    5.6 Specific Checks ..... 5-3

    5.7 Special Inspections ..... 5-19

Chapter 6 - Repair..... 6-1

    6.1 General ..... 6-1

    6.2 Aluminum Parts..... 6-1

    6.3 Steel and Stainless Steel Parts ..... 6-1

    6.4 Specific Repairs ..... 6-1



---

Chapter 7 - Assembly.....	7-1
7.1 General .....	7-1
7.2 Assembly of the FAA/PMA 500F Series Fuel Pump .....	7-1
Chapter 8 - Fits and Clearances .....	8-1
8.1 Torque Values.....	8-1
Chapter 9 - Test and Calibration.....	9-1
9.1 General .....	9-1
9.2 Functional Testing and Calibration .....	9-2
9.3 Final Inspection.....	9-3
Chapter 10 - Special Tools, Fixtures, and Equipment .....	10-1
10.1 Minimum Facility and Tooling Requirements .....	10-1
10.2 Special Tools and Fixtures.....	10-1
Chapter 11 - Illustrated Parts List .....	11-1
11.1 Introduction .....	11-1
11.2 Illustrated Parts List .....	11-1

## List of Figures

Figure 1-1 - Fuel Flow .....	1-2
Figure 1-2 - Fuel Bypass Flow .....	1-3
Figure 1-3 - Fuel Relief Flow .....	1-4
Figure 3-1 - 500F-0001, -0002, 0004 Fuel Pump .....	3-2
Figure 3-3 - Seal Removal .....	3-4
Figure 5-1 - 500F-0001, -0002, -0004 Fuel Pump .....	5-3
Figure 5-2 - Valve Housing .....	5-4
Figure 5-3 - Rotor .....	5-6
Figure 5-3a - Drive Coupling Shaft .....	5-7
Figure 5-3b - Drive Coupling Sleeve .....	5-8
Figure 5-4 - Pump Housing .....	5-9
Figure 5-5 - Pump Liner .....	5-10
Figure 5-6 - Bearing .....	5-11
Figure 5-7 - Bearing .....	5-12
Figure 5-8 - Diaphragm Plate .....	5-13
Figure 5-9 - Bypass Valve .....	5-13
Figure 5-10 - Poppet Relief Valve .....	5-14
Figure 5-11 - Valve Cover .....	5-15
Figure 5-12 - Blade .....	5-17
Figure 5-13 - Locknut .....	5-18
Figure 7-1 - 500F Fuel Pump .....	7-2
Figure 7-2 - Seal Installation .....	7-3
Figure 7-3 - Bearing .....	7-4
Figure 7-4 - Rotor and Blades .....	7-4
Figure 7-5 - Liner .....	7-6
Figure 7-6 - Valve Housing Alignment .....	7-7
Figure 7-7 - Valve Housing Component Arrangement .....	7-9
Figure 7-8 - Retaining Ring .....	7-11
Figure 7-9 - Retaining Ring Position .....	7-11
Figure 9-1 - Flow Bench Schematic .....	9-1
Figure 9-2 - Jam Nut Safetying .....	9-3
Figure 9-3 - Cap Screw Safetying .....	9-4
Figure 9-4 - Screw Safetying .....	9-4
Figure 10-1 - Dimensions for Tool P/N 101F-0001 .....	10-2

---

**List of Figures (cont'd)**

Figure 10-2 - Dimensions for Tool P/N 101F-0002..... 10-3  
Figure 11-1 - 500F-0001, -0002, -0004 Fuel Pump..... 11-3

**List of Tables**

Table 1-1 - Part Identification .....	1-6
Table 1-2 - Operation Specifications.....	1-7
Table 2-1 - Troubleshooting .....	2-1
Table 5-1 - Inspection Criteria.....	5-4
Table 8-1 - Torque Values .....	8-1
Table 9-1 - Relief Valve Settings .....	9-2
Table 11-1 - IPL .....	11-4

This Manual provides service information for Fuelcraft™\* fuel pump components.

Changes and updates to this Manual can be found at [www.fuelcraft.aero](http://www.fuelcraft.aero). Revisions will be tracked and recorded on the List of Affected Pages section of this document.

Should you have a question regarding Fuelcraft fuel pump components, Fuelcraft™ Product Support is ready to assist you. We may be reached at the following contact information:

Phone: +1.334.386.5400 (option 2)

E-mail: [techsupport@Hartzell.aero](mailto:techsupport@Hartzell.aero)

Fax: +1.334.386.5450

Web: [www.fuelcraft.aero/contact/](http://www.fuelcraft.aero/contact/)

\* Fuelcraft™ is a trademark of Hartzell Engine Tech LLC.

### **Warning:**

PEOPLE WHO FLY SHOULD RECOGNIZE THAT THERE ARE VARIOUS TYPES OF RISKS INVOLVED IN THIS ACTIVITY; AND THEY SHOULD TAKE ALL PRECAUTIONS TO MINIMIZE THEM, SINCE THEY CANNOT BE ELIMINATED ENTIRELY.

IT IS ESSENTIAL THAT THE FUEL PUMP IS PROPERLY MAINTAINED ACCORDING TO THE RECOMMENDED SERVICE PROCEDURES AND MONITORED TO DETECT IMPENDING PROBLEMS BEFORE THEY BECOME SERIOUS. ANY UNUSUAL OPERATION SHOULD BE INVESTIGATED AND CORRECTED, AS IT MAY BE A WARNING OF IMPENDING FAILURE.



**Record of Revisions**

Revision Letter	Page(s) Revised	Description	Date
New	All	New Release	06/17/2020
A	Cover	Add fuel pump models supported by this manual;	08/10/2020
	4	Update heading #5. to Calendar Limits, Storage, Acceptance, and Shipping;	
		Change "operational shelf" to "storage";	
	5	Add Pre-Installation Acceptance checks;	
	1-7	Add 500F-002 operation specs to Table 1-2;	
		Add Shipping guidelines;	
	3-1	Add reference only statement to 3.1 C.(1);	
	3-2	Add visual reference to 500F-0002 fuel pump unique components;	
		Update 500F-0001 Illustration to show port plugs ITM #26 and packings ITM #31;	
		Add port plug and packing to nomenclature index;	
	3-3	Add step to discard packings, ITM #31, from port plugs;	
	3-5	Add step to discard O-ring/packing assembly (32) from adjusting screw (17);	
	4-1	Add 150-180 grit selection to Scotch-Brite;	
	5-3	Move Figure 5-1 to pg. 5-4;	
		Add 500F-0002 reference to Figure 5-1;	
	5-8	Update Figure 5-5 callout to match Serviceable Limits in Table 5-1, Pump Liner;	
	5-9	Add callout to Figure 5-6: inspection steps (1) thru (3);	
		Add inspection criteria for 500F-0002 bearing P/N 075F-0011 (4);	
		Add bearing P/N 500F-0002 to Figure 5-6;	
	7-1	Add reference only statement to 7.1 C.(1);	
	7-2	Update 500F Illustration to show port plugs ITM #26 and packings ITM #31;	
		Add fuel pump 500F-0002 reference to Figure 7-1	
		Add port plug and packing to nomenclature index;	
	7-10	Update step 7.2 E.(1) to install packings onto port plugs;	
	8-1	Update P/N of ITM #26, Port Plug;	
	9-2	Add 500F-0002 relief valve settings to Table 9-1;	
	11-3	Add 500F-0002 specific components to Figure 11-1;	
		Add ITM #32 to Figure 11-1;	
	11-4	Add fuel pump P/N 500F-0002 to IPL;	
		Update ITM #26 P/N;	
	11-5	Add ITM #32;	
		Add ITM #s 33 thru 36: 500F-0002 unique components.	



**Record of Revisions**

Revision Letter	Page(s) Revised	Description	Date
B	1-6	Remove references to Overhaul;	07/21/2022
	1-7	Table 1-2, change $575 \pm 5$ to 1,100 MIN; Change $24 \pm 1$ to $30 \pm 2$ ; Change $3250 \pm 50$ to $3,665 \pm 50$ ;	
	9-2	Table 9-1, change $550 \pm 5$ to 550 MIN; Remove post-test setting parameters from Model 500F-0001.	
C	All	Change Hartzell Engine Technologies to Hartzell Engine Tech, all instances;	04/02/2025
	Cover	Add 500F-0004 to fuel pump model covered by this manual;	
	1	Add means of distrobution for this manual;	
	A-1	Correct typo para. A.2 C.(2). Add: and/or installation;	
	1-6	Update serial number breakdown to current standards;	
	1-7	Add 500F-0004 operating specifications to Table 1-2;	
	3-2	Update Fig. 3-1 with new drive coupling design;	
	5-3	Update Fig. 5-1 with new drive coupling design;	
	5-4	Update Fig. 5-2 for clarity;	
	5-5 thru 5-17	Update Table 5-1 to new drive coupling design inspection criteria;	
	5-6	Update Fig. 5-3 to new rotor design;	
	5-7	Update Fig. 5-3a to reflect new drive coupling shaft;	
	5-8	Update Fig. 5.3b to reflect new drive coupling sleeve;	
	7-2	Update Fig. 7-1 with new drive coupling design;	
	7-4	Update Fig. 7-4 to new rotor design;	
	7-10	Update para. (19) & (20) to reflect new drive coupling design;	
	7-11	Update Fig. 7-8 and 7-9 to new drive coupling design;	
	9-2	Add fuel pump model 500F-0004 to Table 9-1;	
	11-3	Update Fig. 11-1 to new drive coupling design;	
	11-4 & 11-5	Update IPL Table 11-1 part numbers to new drive coupling design; Add 500F-0004 fuel pump model to IPL Table 11-1.	
D	11-5	Table 11-1, add circle to ITM# 32 denoting replacement at overhaul; Table 11-1, remove circle from ITM# 35. Part is not required replacement at overhaul.	10/27/2025



**Service Publication List**

Pub. Number	Description	Fuel Pump Affected

THIS PAGE INTENTIONALLY LEFT BLANK

## Introduction

### 1. Statement of Purpose

#### A. General

- (1) This manual provides maintenance and overhaul procedures for 500F model engine driven fuel pumps manufactured by Hartzell Engine Tech LLC (HET).
- (2) Changes and updates to this manual can be found at <https://fuelcraft.aero/>. Revisions will be tracked and recorded in the Record of Revisions section of this document.
- (3) Contact Hartzell Engine Tech LLC about any maintenance problems or to request information not included in this publication.

**NOTE:** When calling from outside the United States, dial (001) before dialing the telephone numbers provided below.

- a) Fuelcraft is a trademark of Hartzell Engine Tech LLC
- b) Hartzell Engine Tech LLC can be reached during business hours (8:00 a.m. through 5:00 p.m., United States Central Time) at (334) 386-5400.
- c) Hartzell Engine Tech LLC can also be reached by fax at (334) 386-5410, and by e-mail at [techsupport@hartzell.aero](mailto:techsupport@hartzell.aero).

#### B. Where possible, this manual is written in the format specified by ATA iSpec 2200.

**CAUTION:** PERSONS ATTEMPTING MAINTENANCE OF ANY SORT MUST BE QUALIFIED LEGALLY AND TECHNICALLY TO PERFORM SUCH WORK AND MUST OBSERVE THE CRITICAL TOLERANCES AND HIGH STANDARDS OF WORKMANSHIP THAT ARE REQUIRED. THE OVERHAULER MUST COMPLY WITH ALL INSTRUCTIONS CONTAINED IN THIS MANUAL TO ASSURE SAFE AND RELIABLE PERFORMANCE OF OVERHAULED COMPONENTS. FAILURE TO COMPLY WILL BE DEEMED MISUSE, THEREBY RELIEVING HET OF ANY RESPONSIBILITY UNDER ITS WARRANTY.

- C. This manual is to be used in FAA-Licensed Repair Stations and by Licensed A&P Mechanics who are trained and experienced with HET products. This manual does not provide complete information for an inexperienced technician to attempt overhaul without supervision.
- D. This manual is intended to be the primary source of maintenance and overhaul information for 500F model fuel pumps manufactured by HET. Information published in Service Bulletins and Service Letters may supersede information published in this manual. The reader must consult active Service Bulletins and Service Letters for information that may not yet have been incorporated into the latest revision of this manual.
- E. The inclusion of vendor names and part numbers in this manual shall not be construed as an authorization of the vendor, pursuant to FAA regulations, to ship directly to the user. Neither shall it be construed as a certification by Hartzell Engine Tech LLC (HET) that parts shipped by vendors directly to users will conform to the type design, or that such parts are airworthy or safe for installation.

- F. Equipment described in this manual must be installed and operated in accordance with the operating limitations and conditions specified in this manual, as well as by any additional instructions supplied by the engine or airframe manufacturers.
  - (1) HET does not accept responsibility for the airworthiness of any aircraft resulting from the installation of an HET fuel pump or associated equipment.
  - (2) Published TBO for the 500F series fuel pumps is based on operation of the engine to normal recommended conditions.
  
- G. Because of numerous field modifications, Supplemental Type Certificates (STC), Parts Manufacturing Approvals (PMA), Technical Standard Orders (TSO), Form 337 Field Approvals, and other documents, the information used in the aircraft application data is for reference only and may not be applicable to every application.
  - (1) For appropriate engine/airframe application, refer to the appropriate Type Certificate (TC) and/or log book.
  - (2) HET liability for use of the authorized data in this manual for repair, overhaul or return to service is limited to the specific terms and conditions stated under the applicable limited warranty policy for each piece part, component, assembly, or unit sold by HET.
  - (3) No liability will be assumed by Hartzell Engine Tech LLC for actual, consequential, or other types of damages directly or indirectly resulting from the unauthorized use of this manual for other than its stated purposes.

## 2. Methods of Identifying Approved Parts

**CAUTION:** IF YOU SUSPECT THAT YOU HAVE RECEIVED OR USED AN “UNAPPROVED PART” REMOVE THE PART FROM SERVICE IMMEDIATELY AND CONSULT WITH THE FAA’S SUSPECTED UNAPPROVED PARTS PROGRAM (SUP). FILE FAA FORM 8120-11 OR AND SUBMIT IT TO: FEDERAL AVIATION ADMINISTRATION OFFICE OF AUDIT AND EVALUATION , AVIATION SAFETY HOTLINE, ROOM 911, 800 INDEPENDENCE AVENUE, SW WASHINGTON D.C. 20591 USA. CONTACT THE AVIATION SAFETY HOTLINE AT TEL: 1-800-255-1111 OR 1-866-835-5322. SUBMIT THE FORM AT EMAIL: 9-AWA-AVS-AAI-SAFETYHOTLINE@FAA.GOV.

- A. The following methods exist for the identification of approved parts:
  - (1) An FAA form 8130-3 Airworthiness tag.
  - (2) An airworthiness approval tag identifies a part or group of parts that have been approved by authorized representatives. An FAA/PMA system, together with the manufacturer’s name, trademark or symbol, part number, and the make and model of the product on which the part is eligible for installation, stamped on the part.
    - (a) An FAA parts manufacturer approval (FAA/PMA) is issued under 14 CFR 21.303.
    - (b) The make and model information may be on a tag attached to the part.
  - (3) A shipping ticket, invoice, or other documents that provide evidence that the part was produced by a manufacturer holding an FAA APPROVED INSPECTION SYSTEM issued under 14 CFR 21, Subpart K, or by a manufacturer holding an FAA production Certificate issued under 14 CFR 21, Subpart G.

- (4) A certificate of airworthiness for export issued by a foreign government under the provisions of 14 CFR 21, Subpart N.

### 3. Required Publications

**CAUTION:** WHEN PERFORMING INSTALLATION, MAINTENANCE, REPAIR, REPLACEMENT, ADJUSTMENT, INSPECTION, OR OVERHAUL OF ANY HET ASSEMBLY, COMPONENT, OR PART, IT IS NECESSARY THAT THE LATEST REVISION OF THE APPROPRIATE HET MANUAL OR OTHER APPLICABLE DOCUMENTS BE REFERENCED. CONTACT HET TO BE SURE YOU HAVE THE LATEST REVISION BEFORE PERFORMING ANY WORK. ALERT SERVICE BULLETINS, SERVICE BULLETINS, SERVICE LETTERS, AND OTHER PUBLICATIONS MAY BE OBTAINED THROUGH THE HARTZELL ENGINE TECH WEBSITE AT WWW.HARTZELL.AERO.

#### A. Hartzell Engine Tech LLC Publications

- (1) In addition to this manual, one or more of the following publications may be required for information regarding specific recommendations and procedures to maintain 500F model engine driven aircraft fuel pumps.
  - (a) No additional HET manuals required.
- (2) Information published in Alert Service Bulletins, Service Bulletins, and Service Letters may supersede information published in this manual. The reader must consult active Alert Service Bulletins, Service Bulletins, and Service Letters for information concerning these procedures that may have not yet been incorporated into the latest revision of this manual.
- (3) For service literature and revisions: <https://fuelcraft.aero/>

Contact:

Hartzell Engine Tech LLC  
2900 Selma Highway  
Montgomery, AL 36108, USA  
Phone: (334) 386-5400  
Fax: (334) 386-5450

#### B. References to Hartzell Engine Tech Publications

- (1) Item references throughout the text in this manual refer to item numbers in the Illustrated Parts List Chapter. The item numbers appear in parentheses directly following the part name. Only the item base number will appear in the text of the manual. Item base numbers and the alpha variants of the base numbers will appear in the illustrated parts list. There are two reasons for the use of alpha variants:
  - (a) A part may be superseded, replaced, or obsoleted by another part.
  - (b) An Illustrated Parts List may contain multiple configurations. Effectivity codes are used to distinguish different part numbers within the same list.

#### C. Vendor Publications

- (1) Not applicable.

#### 4. Personnel Requirements

##### A. Inspection, Repair, and Overhaul

- (1) Compliance to the applicable regulatory requirements established by the Federal Aviation Administration (FAA) is mandatory for anyone performing or accepting responsibility for any inspection and/or repair and/or overhaul of any Hartzell Engine Tech LLC (HET) product.
- (2) Any person signing for or performing inspections, repairs and/or overhauls to HET parts should be very familiar with the objectives and procedures associated with the inspecting, repair, and/or overhaul of parts.
- (3) Persons attempting overhaul work must be appropriately qualified to service these pumps and must observe the critical tolerances and high standards of workmanship that are involved.
- (4) Agencies other than HET performing repair or overhaul must permanently affix their own identification to the unit.
  - (a) This information must include the Repair Station Number and/or Facility Code or equivalent identification number.

#### 5. Calendar Limits, Storage, Acceptance, and Shipping

##### A. Calendar Limits

- (1) All 500F fuel pumps have a storage life of up to, but not to exceed, twelve (12) calendar years at which time the unit must be overhauled.
- (2) HET shelf life for warranty purposes is a maximum of 36 months from date of factory original manufacture or rebuild, after which the warranty is expired.

##### B. Short Term Storage

- (1) Short term storage will be considered as storage of up to but not exceeding thirty-six (36) calendar months.
- (2) If the unit is on the shelf, it must be kept in its original packaging.
- (3) If the unit is on the aircraft or on an unmounted engine, follow procedures identified in the applicable Pratt and Whitney PT6 manual.

##### C. Long Term Storage

- (1) Long term storage will be considered as storage up to but not exceeding twelve (12) calendar years. (Applies to new, rebuilt, or overhaul units.)
- (2) If the unit is stored on the shelf, the pump must be removed from the box and from plastic bag as originally packaged to prevent condensation in the bag during long term storage. (If desiccant is used and no color change from new, the original bag may continue in use.)
  - (a) Discard the bag if required.
  - (b) Remove the shipping caps and fill housing with light machine oil.
  - (c) Do not drain oil.

- (d) Wipe or lightly spray the outside of the unit with preservative oil and grease the spline drive with Dow Corning Molykote® G-n paste or equivalent. (G-n paste is a heavy duty blend of molybdenum disulfide & white lube in mineral oil.)
  - (e) Recap all openings.
  - (f) Wrap the unit tightly with a waxed type paper.
  - (g) Place the unit back into the original shipping container and store in a cool dry environment.
- (3) If it is anticipated or determined that the aircraft or unmounted engine will be in a long-term storage situation, preserve engine and fuel pump in accordance with applicable Pratt and Whitney PT6 manual.
  - (4) Reactivation of the fuel pump after long term storage:
    - (a) Completely remove the oil from the unit.
    - (b) Flush the unit with fresh JET-A or JET-A1.

## 6. Pre-Installation Acceptance

### A. General

- (1) Packaging shall be sealed at receipt with the contents inside protected with packing foam.
- (2) Contents shall be contained in the supplied bag with desiccant.
- (3) Paperwork approval shall be included (Form 8130-3 and pump acceptance testing results).
- (4) Remove pump from packaging and inspect for visible damage or corrosion.
- (5) Ensure coupling is secured to pump with snap ring and ring ends are rotated 90 degrees from slot direction. Verify coupling and rotor joint is lubricated and that no damage is visible outside the limits defined in Table 5-1 for the rotor. No damage is permissible for the coupling.
- (6) Received pumps not meeting the requirements of (1) through (5) shall not be installed. Notify HET of any part not meeting these requirements.

## 7. Shipping

### A. General

- (1) When shipping any fuel pump, drain any fluids and cap all ports.
- (2) Place in a sealed bag with Desiccant.
- (3) Place fuel pump in a suitable shipping container with an appropriate amount of packaging foam to ensure the pump is safely contained.
- (4) Contact HET for shipping instructions.

## 8. Component Life and Service

### A. Overhaul

- (1) Overhaul is the periodic disassembly, cleaning, inspecting, repairing as necessary, reassembling, and testing in accordance with approved standards and technical data approved by the administrator.
- (2) The overhaul interval is based on hours of service (operating time) or on calendar time. At such specified periods, the fuel pump should be completely disassembled and inspected for cracks, wear, corrosion, and other unusual or abnormal conditions. As specified, certain parts should be repaired, and certain other parts such as O-rings and diaphragm should be replaced.

**CAUTION:** DO NOT USE OBSOLETE OR OUTDATED INFORMATION. PERFORM ALL INSPECTIONS OR WORK IN ACCORDANCE WITH THE MOST RECENT REVISION OF THIS MANUAL. INFORMATION CONTAINED IN THIS MANUAL MAY BE SIGNIFICANTLY CHANGED FROM EARLIER REVISIONS. USE OF OBSOLETE INFORMATION MAY RESULT IN DEATH, SERIOUS BODILY INJURY, AND/OR SUBSTANTIAL PROPERTY DAMAGE.

- (3) Overhaul must be completed in accordance with the latest revision of this component maintenance manual and other applicable publications as may be referenced in this component maintenance manual.

### B. Component Life

- (1) The time between overhaul (TBO) for the 500F aircraft fuel pump shall coincide with Pratt and Whitney PT6A Hot Section Inspection (HSI) and engine overhaul intervals, as applicable to specific engine model, or twelve (12) years time in service, whichever occurs first.
- (2) If time in service is unknown, overhaul or replace the fuel pump.
- (3) It is recommended that all 500F fuel pumps of any part number be removed from the engine and be sent for inspection and overhaul to a properly certificated part 145 repair station, or foreign equivalent, that is experienced in fuel systems.
- (4) HET does not permit extension of the component TBO.
- (5) Component Life is a recommendation not a Limitation.

**9. Definitions**

<u>Term</u>	<u>Definition</u>
Bypass Valve.....	The bypass valve provides a fuel flow path from the pump inlet to the outlet around the core pumping elements. The bypass valve is held closed by the pressure of the fuel on the discharge side of the pump when the pump is operating normally. Conditions where this action may occur are during priming for engine start and while operating the auxiliary boost pump in the event of engine driven pump failure.
Cleaning Solvent.....	Non-flammable, carbon-removal type of solvent suitable for general cleaning of exterior surfaces of the fuel pump.
Crocus Cloth .....	A mildly abrasive metal-polishing cloth impregnated with jeweler's rouge, a dark red ferric oxide powder.
Detrimental Condition .....	Any condition that is adverse to normal operation, including but not limited to, sticking, leaking, scarring, cracking swelling, and impeded rotation.
Drag Torque .....	Minimum torque required to move one threaded part along the threads of the mating part before tightening actually begins.
Fuel Pump.....	The basic purpose of the pump is to provide a continuous supply of fuel at the proper pressure at all times during the operation of the aircraft engine. HET fuel pumps are of the eccentric, sliding vane, positive displacement style.
Galling .....	Damage in which two metal surfaces rub against each other so that material leaves one surface and deposits on the other surface.
General Condition .....	Overall examination for obvious flaws or damage, which includes but is not limited to leaks, discolorations, cracks, corrosion, surface finish, and mechanical damage.
Hone .....	Tool for enlarging holes to precise tolerances and controlling finishes by means of a mechanically rotated abrasive.
Liner .....	A precisely machined steel cylinder with a large elliptical hole formed in the center. The liner wall has slots in each side (inlet/outlet) for fuel flow and a slot in the thickest section of the wall to allow a pin to halt any possibility of liner rotation. The elliptical hole in conjunction with the rotor and vanes provide a crescent shaped space that forms the pumping chamber.

- Magnetic Particle Inspection .....A method for testing for cracks and subsurface defects in ferrous material such as steel. In MPI, a magnetic field is induced into the article being tested. Magnetic fields are created which are composed of flux lines that flow through the magnetized test article. These flux lines can deflect and leak out in the vicinity of a surface or near surface flaw. When iron powder is introduced, the magnetic flux leakage attracts the iron particles, which will then cluster at the flaw to form an indicator.
- Noncaustic Cleaning Solution .....Solution for cleaning disassembled parts of fuel pumps, free of caustic chemicals which could react with aluminum.
- Overhaul (fuel pump) .....An overhaul consists of the complete disassembly of the fuel pump, which includes inspection, repairs as necessary, reassembly, tests, and approval for return to service within the fits and limits specified by the manufacturer’s overhaul data. This must also incorporate any replaced parts, regardless of condition, if a result of a manufacturer’s overhaul data, Service Bulletin, or an Airworthiness Directive (AD).
- Parts Manufacturer Approval .....(PMA) is a combined design and production approval for modification and replacement parts. It allows a manufacturer to produce and sell these parts for installation on type certificated products. PMA is granted by the FAA and generally accepted by other foreign aviation authorities.
- Relief Valve .....The relief valve provides a variable bypass re-circulation channel for the fuel. Its purpose is to bypass excess fuel to the intake side of the pumping element and to make sure that a sufficient amount of fuel is fed to the engine at all power settings. The pump compensates for any overabundance of fuel by re-circulating fuel within the pump body via the relief valve.
- Rotor .....Rotating drive shaft with single drive slot coupled to a shear section drive spline. The rotor contains a slotted barrel in which four slots are machined to receive the pump vanes.
- Scoring .....Scratches in the direction of repeated motion; for instance, circumferential scratches on a rotating shaft.
- Alert Service Bulletin (ASB) .....Document issued by Hartzell Engine Tech LLC, that describes critical, mandatory procedures or information that must be observed for safety reasons.
- Service Bulletin (SB) .....Document issued by Hartzell Engine Tech LLC, that describes procedures or information that must be observed for economic and/or safety reasons.

---

Service Letter (SL) .....	Document issued by Hartzell Engine Tech LLC, that describes service policies, enhancement kits, order and availability information, contact information changes, and new products.
Service Limits.....	Limits of wear for a serviceable component. If, for instance, the inside diameter of a component is worn beyond the maximum service limit for that dimension, it must be replaced. For an outside diameter, the service limit dimension is a minimum.
Time Between Overhauls (TBO).....	Time interval established by the component or engine manufacturer as the number of hours time in service after which the component or engine must be overhauled. May be established in hours total time in service or calendar time.
Time In Service (TIS) .....	The time in hours of operation that an engine, airframe, or component is used according to the time keeping device installed. May be recording tachometer, flight timer (from start, weight off wheels, or gear up) or any other device for recording time.
Unscheduled Repair .....	Any time a repair is required to restore pump to airworthy condition, except at scheduled time, such as TBO.
Vane .....	A rectangular plate designed to move freely in and out of a precisely machined slot in the rotor. The camcontoured bore of the liner along with the sliding fit of the vanes in the rotor shaft slots assure that the ends of the vanes remain in intimate contact with the pump liner at all times.

## 10. Abbreviations

<u>Abbreviation</u>	<u>Term</u>
ATA.....	Air Transport Association
CW .....	Clockwise rotation (turning to the right as referenced by viewing the drive end of the pump from the pump mounting flange end).
Drv-Cpl Assy .....	Drive Coupling Assembly
FAA .....	Federal Aviation Administration
FPI .....	Fluorescent Penetrant Inspection
Ft-Lb.....	Foot-Pound
HET .....	Hartzell Engine Tech LLC, located at 2900 Selma Highway, Montgomery, Alabama 36108, USA.
I.D. ....	Inside Diameter
In-Lb.....	Inch-Pound
IPL.....	Illustrated Parts List
Lbs .....	Pounds
NAS.....	National Aircraft Standards
N•m .....	Newton-Meter
OD.....	Outside Diameter
PMA .....	Parts Manufacturer Approval
PSI .....	Pounds per Square Inch
RPM .....	Revolutions Per Minute as used to describe the rotational speed supplied from a rotating shaft or gear to shaft.
TBO.....	Time Between Overhaul
TIS .....	Time in Service

## Airworthiness Limitations

### A.1 Airworthiness Limitations Statement

- A. The Airworthiness Limitations section is FAA approved and specifies maintenance required under §§43.16 and 91.403 of the Federal Aviation Regulations unless an alternative program has been FAA approved.

### A.2 Life Limits

- A. The FAA establishes specific life limits for certain component parts as well as the complete fuel pump. Such limits require replacement of the identified parts after a specified number of cycles or hours of use.
- B. Additions of, or changes to, any life limit for the fuel pump components will be noted in the Airworthiness Limitation Revision Log.
- C. Life Limits
  - (1) Fuel pump models and their component parts affected by this manual currently do not have any life limited parts.
  - (2) There are no new (or additional) Airworthiness Limitation associated with this equipment and/or installation.

### AIRWORTHINESS LIMITATION REVISIONS LOG

Revision Number	Description of Revision

## Chapter 1 - Description and Operation

### 1.1 Description

#### A. General

The 500F Series Fuel Pumps manufactured by Hartzell Engine Tech LLC are of the eccentric, sliding vane, positive displacement style. Pumps of this type are widely used in aircraft fuel systems. Though similar in design and function, each pump in the 500F series are tailored to meet the exacting requirements and demands for its specific application.

### 1.2 Operation

#### A. Fuel Pump Part Number

The basic purpose of the fuel pump is to provide a continuous supply of fuel at the proper pressure at all times during the operation of the aircraft engine. Since the pump is symmetrical about a horizontal axis, it is capable of pumping fuel in either direction with equal efficiency.

Each pump part number has a specific clockwise (CW) rotation. The rotation is based on stated engine rotation for the PT6A vacuum scavenge pump pad. The pump ports have cast markings identifying inlet and outlet.

The 500F fuel pump has three basic elements in operation. The pumping element, the bypass valve, and the relief valve. Each is contained in a light weight housing designed to allow variations in position and rotation to maximize usage.

#### (1) Pumping Elements

*Refer to Figure 1-1 - Fuel Flow*

Fuel enters the pump at the inlet and is swept through the pump by the sliding action of a pair of opposed vanes. These vanes (blades) slide freely in slots machined into the rotor barrel. Both rotor and vanes are supported on either end by bearings that enclose the pumping chamber.

The cam-contoured bore of the liner, along with the sliding fit of the vanes in the rotor shaft slots, assure that the ends of the vanes remain in close contact with the pump liner at all times.

The rotor is eccentrically positioned within the liner bore creating a crescent shaped space that forms the pumping chamber.

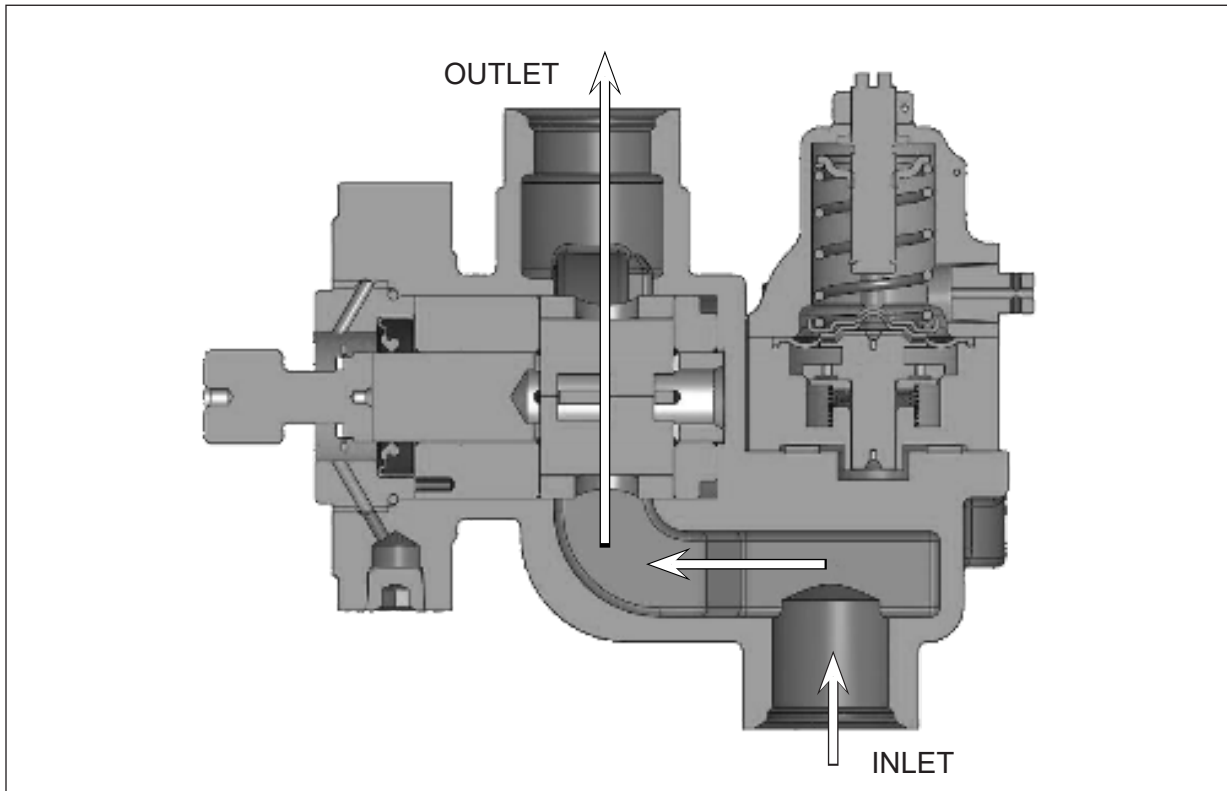

**Figure 1-1 - Fuel Flow**

(2) Bypass Valve

The 500F fuel pump bypass valve is a lightly spring-loaded stainless steel disc. The pumping element and the bypass system are in parallel with each other. In Figure 1-2, fuel is shown bypassing the pumping element through the passage holes drilled circumferentially around the inner diameter of the bypass valve.

The bypass valve is held closed by the pressure of the fuel on the discharge side of the pump when the pump is operating normally. When the engine driven pump is inoperative, i.e., when the pump shaft is not rotating, stationary vanes prevent fuel from passing from the inlet through the core pump to the outlet.

The bypass valve provides a fuel flow path from the pump inlet to the outlet around the core pumping elements. This action may occur during priming for engine start and while operating an auxiliary boost pump in the event of engine driven pump failure.

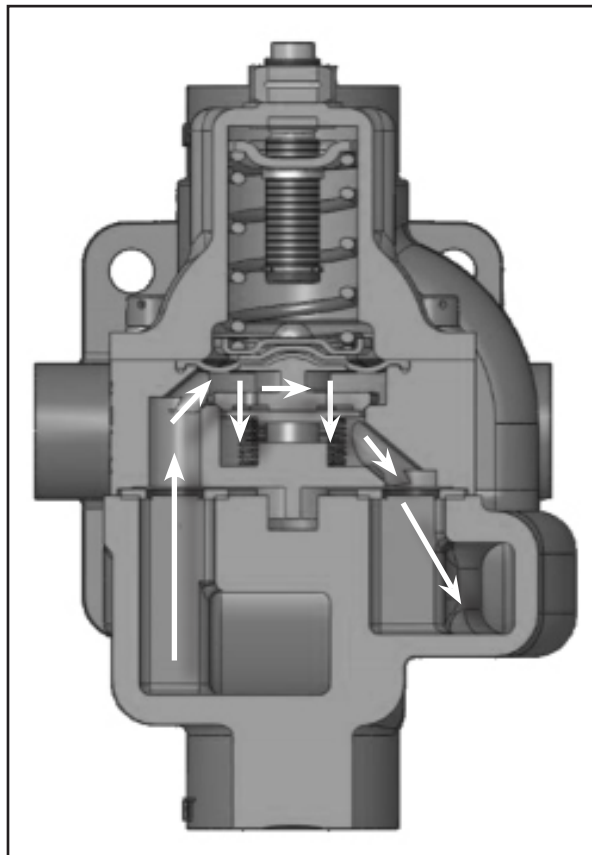

**Figure 1-2 - Fuel Bypass Flow**

(3) Relief Valve

The 500F model fuel pump is capable of supplying fuel in excess of engine demand. By means of a relief valve, the pump compensates for any overabundance of fuel by recirculating fuel within the pump body.

The relief valve provides a variable bypass recirculation channel for the fuel. This valve is placed in parallel with the core pumping element. Its purpose is to return excess fuel to the intake side of the pumping element and to make sure that a sufficient amount of fuel is fed to the engine at all power settings.

The fuel enters at the inlet port and passes out of the outlet port. If the pressure at the discharge side of the pump is greater than that for which the relief valve is set, the valve is raised off its seat against the pressure of its closing spring. Fuel passes through the opening created and then back to the inlet side of the pump. The arrows in Figure 1-3 indicate the path of the fuel through the valve.

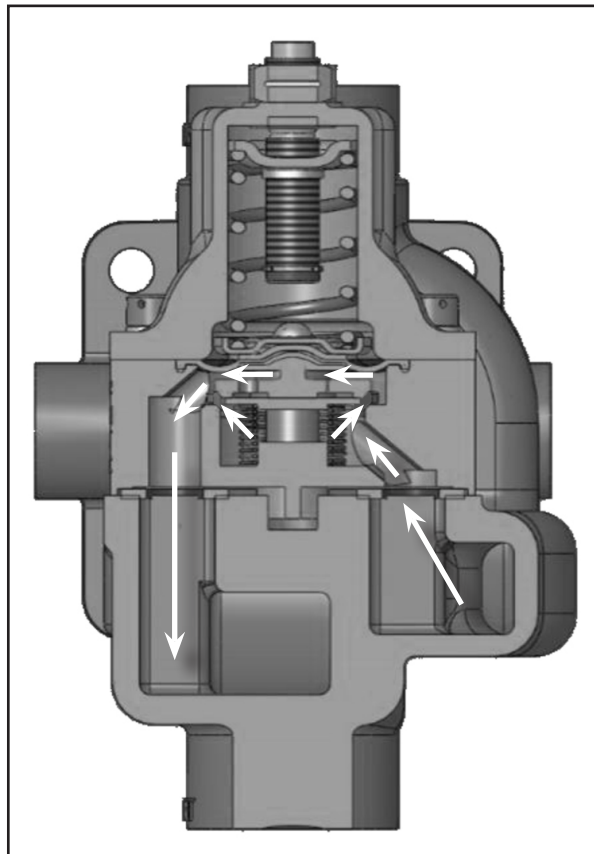

**Figure 1-3 - Fuel Relief Flow**

### 1.3 Parts Identification

#### B. HET Part Number

- (1) The information in this section explains the current method of part numbering and name plate identification and serialization. Refer to Table 1-1 (Examples).
- (2) Blank name plates are available from HET but must be filled out properly if used.
- (3) The HET part number contains eight-digits.
  - (a) The prefix numbers identify the basic pump series followed by a dash.
  - (b) The numbers following the dash, identify the specific pump configuration.
  - (c) An upper case "R" suffix on the part number denotes the unit is factory overhauled.

#### C. Data Tag Identification

- (1) A black name plate showing the engine manufacturer's part number or the HET part number, or both, identifies a new 500F fuel pump assembly.
- (2) A blue name plate is used to identify a factory-rebuilt unit.
- (3) A red colored data tag identifies a factory-overhauled pump.

D. Serial Number Breakdown

- (1) Refer to Table 1-1 for an explanation of the components of the pump assembly serial number.
- (2) When a new unit is factory rebuilt or overhauled, a new serial number will be issued. Refer to the tag color and date stamp.

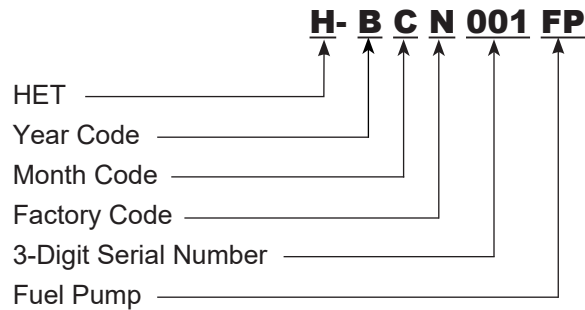

<b>Year Code</b>	B = 2024, C = 2025, D = 2026, etc.
<b>Month Code</b>	A = January, B = February, C = March, etc.
<b>Serial Number</b>	3-Digit Sequential Number

**Table 1-1 - Part Identification**

Examples:

	<b>NEW:</b>	<b>Overhauled:</b>
Part Number:	500F-0001	500F-0001R
Serial number:	H-BEN001FP	H-CCN001FP
Date of Mfg.:	May, 2024	March, 2025

**1.4 Specification for Fuel Pump Operation**

- A. Table 1-2 provides the basic operating specifications for the 500F fuel pump. These specifications show the maximum and minimum values for fuel flow, fuel pressure, RPM, and respective relief valve adjustment settings.

Model No. 500F-	Flow (PPH)	Discharge Pressure (PSIG)	Speed (RPM)	Rotation	Inlet/Outlet Port Size	Unit Weight (Lbs)
0001	1,100 MIN	30 ± 2	3,665 ± 50	CW	7/8 - 14 UNJF-3B	2.2
0002	1,300 MIN	28 ± 2	3,250 ± 50	CW	7/8 - 14 UNJF-3B	2.2
0004	820 MIN	18-22	3,900 ± 50	CW	7/8 - 14 UNJF-3B	2.2

**Table 1-2 - Operation Specifications**

**1.5 Use of Non-HET Certified Parts**

**CAUTION:** IF YOU SUSPECT THAT YOU HAVE RECEIVED OR USED AN “UNAPPROVED PART” REMOVE THE PART FROM SERVICE IMMEDIATELY AND CONSULT WITH THE FAA’S SUSPECTED UNAPPROVED PARTS PROGRAM (SUP). FILE FAA FORM 8120-11 OR AND SUBMIT IT TO: FEDERAL AVIATION ADMINISTRATION OFFICE OF AUDIT AND EVALUATION, AVIATION SAFETY HOTLINE, ROOM 911, 800 INDEPENDENCE AVENUE, SW WASHINGTON D.C. 20591 USA. CONTACT THE AVIATION SAFETY HOTLINE AT TEL: 1-800-255-1111 OR 1-866-835-5322. SUBMIT THE FORM AT EMAIL: 9-AWA-AVS-AAI-SAFETYHOTLINE@FAA.GOV.

- A. Use of any non-HET certified parts, constitutes altering or modifying the fuel pump and voids all warranties.
- B. Hartzell Engine Tech LLC will be relieved of any product liability responsibility for any fuel pump that has non-HET authorized parts or any other unapproved part installed, as deemed by the FAA.
- C. The overhauler will assume full and complete liability for the fuel pump if unauthorized parts are used.
- D. Hartzell Engine Tech LLC is not responsible for damage or harm to the aircraft or its occupants from such an altered or modified fuel pump.

THIS PAGE INTENTIONALLY LEFT BLANK

## Chapter 2 - Troubleshooting

### 2.1 General

- A. The purpose of this chapter is to help isolate probable causes and suggest possible corrective actions for some of the more common fuel pump service problems.
- B. In all cases, the corrective action for a problem should follow the procedures in the applicable sections of this manual.

Symptom	Probable Cause	Corrective Action
Air Leakage:	Loose cover screws or locknut.	Verify the correct torque and tighten the screws or locknut to the specified torque values as required.
Low or Unstable Fuel Flow:	Contamination between the poppet relief valve and the seat.	Disassemble the relief valve assembly and inspect the seating area for contamination. Clean the valve and seat and use 600-1000 grit lapping compound to dress the poppet to relief valve seat.
	Air leak in test bench or airframe.	Bleed air from the system and inspect all hoses and lines for tightness.
	Damaged pump blades.	Inspect pump vanes for chips, gouges, or deep scoring. Replace blades if these conditions exist.
Specified pressures not obtainable:	Relief valve is sticking open.	Examine the condition of the poppet relief valve and seat assembly for contamination on the seat or on the poppet relief valve face or stem. Replace the parts if necessary.
	Damaged pump blades.	Inspect pump vanes for chips, gouges, or deep scoring. Replace blades if these conditions exist.
	Incorrect gauge readings.	Do a check of the accuracy of the test stand instruments. Instrument accuracy must be within +/- 2% of the reading.
Pump is noisy or runs hot:	Possible foreign object damage to pumping mechanism or rotor rubbing condition.	Completely disassemble and inspect the pump for foreign matter and damage. Use FPI or MPI as required to expose cracks or defects.
Leaking rotor shaft seal:	Improperly installed or faulty seal.	Install a new rotor shaft seal.
	Poor rotor shaft surface finish.	Inspect the rotor shaft for surface finish abnormalities. Refer to the Check chapter of this manual for inspection criteria.

Table 2-1 - Troubleshooting

THIS PAGE INTENTIONALLY LEFT BLANK

## Chapter 3 - Disassembly

### 3.1 General

- A. Disassembly, cleaning, and inspection must be performed in a clean environment, free of excessive dust, moisture, or contaminants.
- B. Always refer to the instructions in this manual prior to performing repairs, overhauls, or testing of a fuel pump
  - (1) Information in this section applies to FAA/PMA approved 500F pumps.
- C. Use of Illustrated Parts Lists (IPL)
  - (1) Illustrations in this chapter are for disassembly reference only. Refer to Chapter 11 for ordering of parts.
- D. Identification Tag Replacement
  - (1) When performing a field overhaul or repair, replacement of the data tag (nameplate) with a new data tag stamped with the performing facility information and repair station number, as well as all other applicable data on the existing data tag is required.
    - (a) The nameplate must be stamped with the words "Field-Overhauled".
    - (b) Blank nameplates are available from HET but must be filled out properly.
    - (c) The nameplate may be locally manufactured, but must be approved by a local civil aviation authority before the fuel pump is returned to service.
- E. Removal of the Fuel Pump Assembly from the Engine
  - (1) Remove the fuel pump in accordance with the instruction in the applicable OEM engine service instruction and/or the aircraft maintenance manual.
  - (2) Mark Before Disassembly
    - (a) Make a record of the serial number and model number of the pump and compare it with the data in the engine or airframe logbook.
    - (b) To verify proper re-installation, mark or tag the location of engine fuel lines and install protective caps and plugs.

**NOTE**

ILLUSTRATION IS FOR  
 REFERENCE ONLY,  
 REFER TO CHAPTER 11  
 FOR PARTS ORDERING

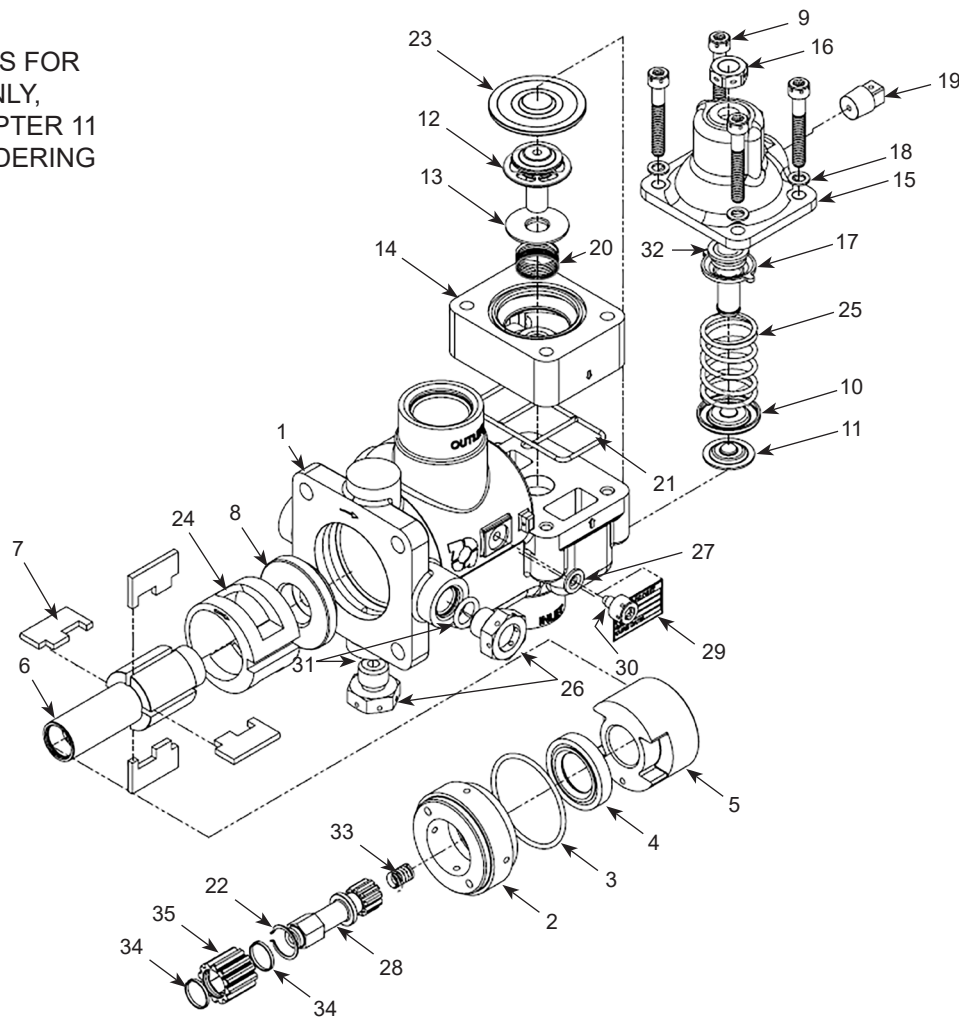

**Figure 3-1 - 500F-0001, 500F-0002, & 500F-0004 Fuel Pump**

1. Housing, Fuel Pump	10. Seat, Spring	19. Plug	28. Drive Coupling
2. Locknut	11. Plate, Diaphragm	20. Spring	29. Data Tag
3. Packing	12. Poppet	21. Gasket, Valve	30. Screw
4. Seal	13. Valve, Bypass	22. Ring, Retaining	31. Packing
5. Bearing	14. Housing, Valve	23. Diaphragm	32. O-Ring Washer Assy
6. Rotor	15. Cover, Valve	24. Liner	33. Spring, Compression
7. Blade, Pump	16. Nut, Jam	25. Spring	34. Ring, Retaining
8. Bearing	17. Screw, Adj. Assy.	26. Plug, Port	35. Sleeve, Coupling
9. Screw, Cap	18. Washer	27. Packing	

### 3.2 Disassembly of the 500F Series Fuel Pump

#### A. General

- (1) The following disassembly procedures are applicable to all FAA/PMA approved 500F Series fuel Pumps.

#### B. Procedure

*Refer to Figure 3-1 as it relates the following tasks*

- (1) Remove and discard all safety wire (lock-wire) from the fuel pump.
- (2) Remove all fittings from the fuel pump.

**CAUTION 1:** FITTINGS & PLUGS MAY BE HELD IN PLACE WITH LOCTITE® SEALANT. SPECIAL PROCEDURES, INCLUDING HEAT, MAY BE REQUIRED TO REMOVE SOME FITTINGS OR PLUGS. REFER TO THE MANUFACTURER'S SAFETY DATASHEET (SDS) FOR LOCTITE® 565/569 DETAILS.

**CAUTION 2:** TO PREVENT DAMAGE TO THE FUEL PUMP HOUSING, DO NOT USE A BENCH VISE TO DIRECTLY HOLD AN ASSEMBLED PUMP TO REMOVE FITTINGS.

- (3) If required, remove all plugs (19 & 26) and shipping plugs from the pump housing (1) and the valve cover (15). Discard packings (31) from port plugs (26).
- (4) Remove screw (30) from fuel pump housing (1). Remove and discard packing (27) from screw (30).

#### C. Pump Disassembly

- (1) Remove and discard retaining ring (22) from the drive coupling assembly (28).
- (2) Remove and discard the drive coupling assembly (28) from the rotor (6).
- (3) Using a spanner wrench (pin size: 1/8 in., 2.9 mm), remove locknut (2).
- (4) Remove and discard seal (4) and packing (3) from locknut (2).
  - (a) Place the locknut (2) on an arbor press with the spanner side facing up.

**NOTE:** A sealant has been applied to the O.D. of the seal assembly that may cause some initial resistance. Refer to Figure 10-2 in the Special Tools, Fixtures, and Equipment chapter of this manual for dimensions for Seal Removal and Installation Tool, Part Number 101F-0002.

- (b) Using the arbor press and HET seal removal tool P/N: 101F-0002, press the seal (4) from the locknut (2). Refer to Figure 3-3.

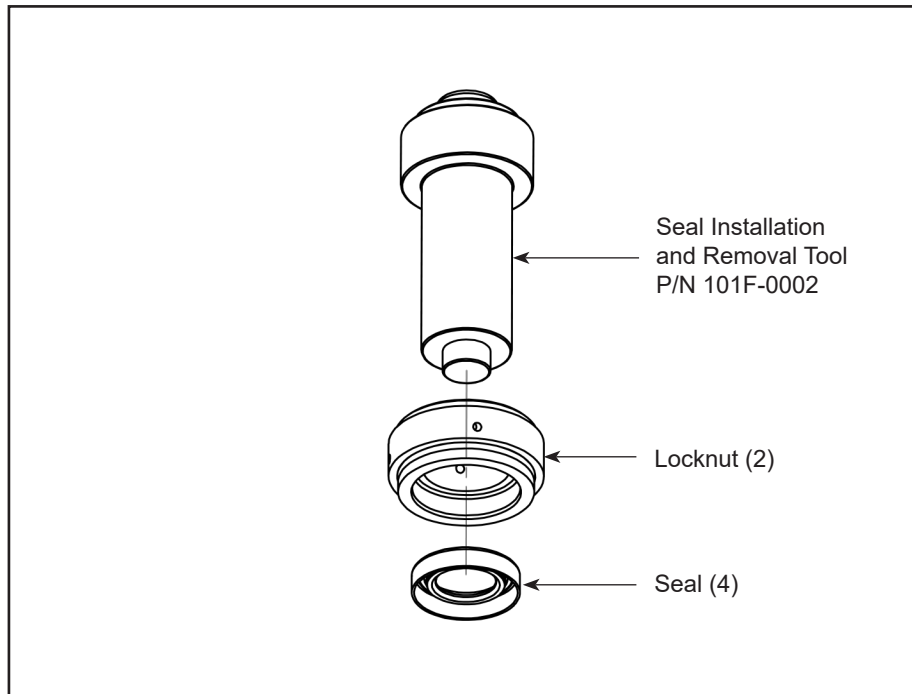

Figure 3-3 - Seal Removal

- (5) Remove the rotor (6) and bearing (5) from the pump housing.

**CAUTION:** TO PREVENT DAMAGE TO THE PUMP BLADES (7), CARE SHOULD BE TAKEN WHILE REMOVING THE ROTOR (6) FROM THE PUMP HOUSING (1).

- (6) Remove the four pump blades (7) from the rotor (6).  
(7) Remove the bearing (5) from the rotor (6).

**CAUTION:** TO PREVENT BINDING AND SCORING OF INTERNAL COMPONENTS, SCREW (30) MUST BE REMOVED PRIOR TO REMOVING THE LINER (24).

- (8) Remove the liner (24) and bearing (8) from the pump housing (1)

#### D. Disassembly of the Relief Valve

- (1) Remove jam-nut (16) from the relief valve adjusting screw (17).  
(2) Rotate the adjusting screw assembly (17) counter clockwise until reaching the internal screw stop. This will relieve tension on the relief valve spring (25).

**NOTE:** The adjusting screw assembly (17) has an internal stop that is held in place in the valve cover (15).

**CAUTION:** DO NOT DAMAGE THE MATING SURFACES OF THE VALVE HOUSING (14) OR VALVE COVER (15). REMOVAL OF THE VALVE HOUSING (14) OR VALVE COVER (15) FROM THE MAIN BODY OF THE FUEL PUMP MAY REQUIRE TAPPING WITH A PLASTIC OR RAWHIDE MALLET OR SIMILAR INSTRUMENT TO SEPARATE THE PARTS.

- (3) Remove four cap screws (9) and four washers (18) and separate the valve housing (14) and valve cover (15) from the pump housing (1).
- (4) Detach the valve cover and nut assembly (15) from the valve housing (14).
- (5) Remove and discard the diaphragm (23).
- (6) Disassemble the remaining parts from the valve housing (14):
  - (a) Remove poppet (12) and bypass valve (13).
  - (b) Remove spring (20).
  - (c) Remove diaphragm plate (11) and spring seat (10).
  - (d) Remove the relief valve spring (25).
  - (e) Remove adjusting screw (17) from valve cover (15).
    - 1) Remove and discard O-ring/packing assembly (32) from adjusting screw (17).
- (7) Using a non-metallic scraper, remove and discard data tag (29).
  - (a) Field overhauls or repairs require a new or locally produced replacement data tag.
- (8) Remove and discard gasket (21) from the valve housing (14).

THIS PAGE INTENTIONALLY LEFT BLANK

## Chapter 4 - Cleaning

### 4.1 General

**WARNING:** ALWAYS USE APPROVED CLEANING AGENTS IN A WELL VENTILATED AREA, SINCE THEY CAN BE HARMFUL TO THE RESPIRATORY TRACT. PROTECT SKIN AND EYES FROM PROLONGED EXPOSURE TO THESE CHEMICALS. KEEP CHEMICALS AWAY FROM OPEN FLAME OR HEAT SOURCE AND STORE IN APPROVED METAL CONTAINERS.

- A. Use of ultrasonic cleaners, vapor degreasers, or petroleum-based solvents are all approved methods for cleaning 500 Series fuel pump parts.
- B. Spray or swab parts waiting for inspection and reassembly with a coating of preserving oil to prevent oxidation or corrosion.

### 4.2 Specific Cleaning Instructions

**CAUTION:** DO NOT DAMAGE THE POPPET (12) AND BYPASS VALVE (13) DURING THE CLEANING PROCESS.

#### A. Cleaning all fuel pump parts

- (1) After disassembly of the fuel pump, either ultrasonically clean all parts in a solution designed for ultrasonic cleaning units or gently agitate immersed parts in a petroleum-based solvent for approximately fifteen minutes.
  - (a) If corrosion is present on a part, immerse the part in a hydrocarbon solvent or a chlorinated solvent equivalent. (No more than 15 min. for non-ferrous parts.) Except time, this method applies to any aluminum or ferrous part any surface.
  - (b) If corrosion cannot be removed by immersing a part in a hydrocarbon solvent or a chlorinated solvent equivalent, replace the part. 150-800 grit Scotch-Brite® may used after immersing. DO NOT machine or grind off corrosion.
- (2) Remove parts from the cleaning solution bath and hand scrub them with a stiff, non-metallic bristle brush to help remove residual grease, dust, dirt, and grime.

**WARNING:** COMPRESSED AIR SHOULD NOT BE GREATER THAN 30 PSI WHEN DRYING PARTS. ALWAYS WEAR ADEQUATE EYE PROTECTION WHEN USING SHOP AIR TO DRY PARTS.

- (3) Dry parts thoroughly using clean, filtered, oil-free, compressed shop air. (Use low pressure air 30 PSI or lower.)

#### B. Cleaning steel parts

- (1) Polish steel parts (liner, rotor, and drive couplings) with a cloth buffing wheel or by use of crocus cloth.
- (2) Make sure not to break or round sharp edges when polishing steel parts.
- (3) Clean parts again after polishing is complete.

PAGE INTENTIONALLY LEFT BLANK

## Chapter 5 - Checks

### 5.1 General

- A. Perform all inspections in a clean environment free of contaminants, dust, or excessive moisture. All measurements must be done in stabilized room temperature, preferably not below 59°F (15°C) ICAO standard day.
- B. Clean components in accordance with the Cleaning Chapter of this manual prior to inspecting.
- C. Inspections specified in this chapter must be performed in conjunction with the Testing and Assembly chapters of this manual.
- D. Inspections must be done on components in accordance with the instructions in this chapter, both before and after any repair of a component is performed.
- E. The Item number and the part description in this chapter reference the Item and part description in the Illustrated Parts List chapter of this manual.
- F. The feature describes the area of inspection. The Inspection indicates the condition or dimension to inspect for.
- G. The Ref. Fig. references the illustration with notes and specific dimensions where applicable.

### 5.2 Inspection Interval Requirements

- A. General
  - (1) Refer to the Airworthiness Limitations Chapter of this manual for information on life limited components and mandatory inspections.
  - (2) Additional mandatory inspections and inspection intervals are in accordance with applicable FAA Airworthiness Directives (AD) and HET service publications.
  - (3) At the time of this revision, there are no FAA mandatory life limited components required for HET 500F series fuel pumps.
- B. Periodic Inspections
  - (1) There are no periodic inspections for the 500F series fuel pumps.

### 5.3 Inspection Requirements - 500F Series Fuel Pumps

- A. General
  - (1) After disassembly of the fuel pump and before inspection, clean all parts in accordance with the Cleaning chapter of this manual
  - (2) Parts that require replacement at each overhaul are identified in the Illustrated Parts List chapter of this manual.

- (3) Parts that fail to meet dimensional requirements specified in this chapter must be replaced.
- (4) If there is any question as to the serviceability or integrity of a part, it should be replaced.
- (5) Use micrometers and calipers to measure the specific critical dimensions as specified in this chapter.
- (6) Use common measurement tools capable of measuring in inches up to four decimal places (0.0000) where required.

**B. Visual Inspection**

- (1) Visually examine parts for obvious damage, such as cracks, distortion, chipping, bends, breaks, pitting, or other wear conditions.
- (2) Visually examine all parts for general serviceability.

**C. Magnetic Particle Inspection (MPI)**

*Steel or other ferrous metals only*

- (1) Use MPI to inspect for cracks or subsurface defects in steel or ferrous metal parts not replaced at overhaul. If fuel pump has been involved in an accident or sudden stoppage, use MPI to inspect the steel rotating parts and replace drive coupling (22).
- (2) It is critical that all parts be demagnetized after MPI inspection. Use common degaussing equipment to assure no residual magnetic field remains.
- (3) Popular manufacturers of MPI include Magnaflux using the MAGNAGLO kit.
  - (a) The manufacturer includes complete instruction for use of their products.

**D. Fluorescent Penetrant Inspection (FPI)**

- (1) Use FPI to inspect for cracks or surface defects in most metal parts not replaced at overhaul. If a fuel pump has been involved in an accident or sudden stoppage, use FPI to inspect the housings. Apply FPI in accordance with ASTM E1417 latest revision.
- (2) To make sure of proper FPI inspection, Level II classroom training and on the job training is recommended.
- (3) Popular manufacturers of FPI include Magnaflux Zyglo, using the ZA-70 kit, and Spot check using the SK-5 kit.
  - (a) These manufacturers include complete instruction for use of their product.

**5.4 Replacement Requirements**

- A. If a component does not meet the permitted Serviceable Limits specified in Table 5-1 in this chapter and cannot be repaired within the Serviceable Limits, the component must be replaced.

**5.5 Repair**

- A. Repairable part defects are specified in the Corrective Action column of Table 5-1 and Table 5-2 in this chapter. Repair procedures are found in the Repair chapter of this manual, unless otherwise stated.

### 5.6 Specific Checks

- A. Refer to Component Inspection Criteria Table 5-1 in this Chapter for specific component checks.
- (1) The “Inspect” column specifies the inspection criteria for each component that is not designated in the Illustrated Parts List chapter to be replaced at overhaul.
  - (2) The “Serviceable Limits” column specifies the permitted limits for each inspection performed on the component.
  - (3) The “Corrective Action” column specifies the disposition of each component that is inspected, based on the serviceable limits given.

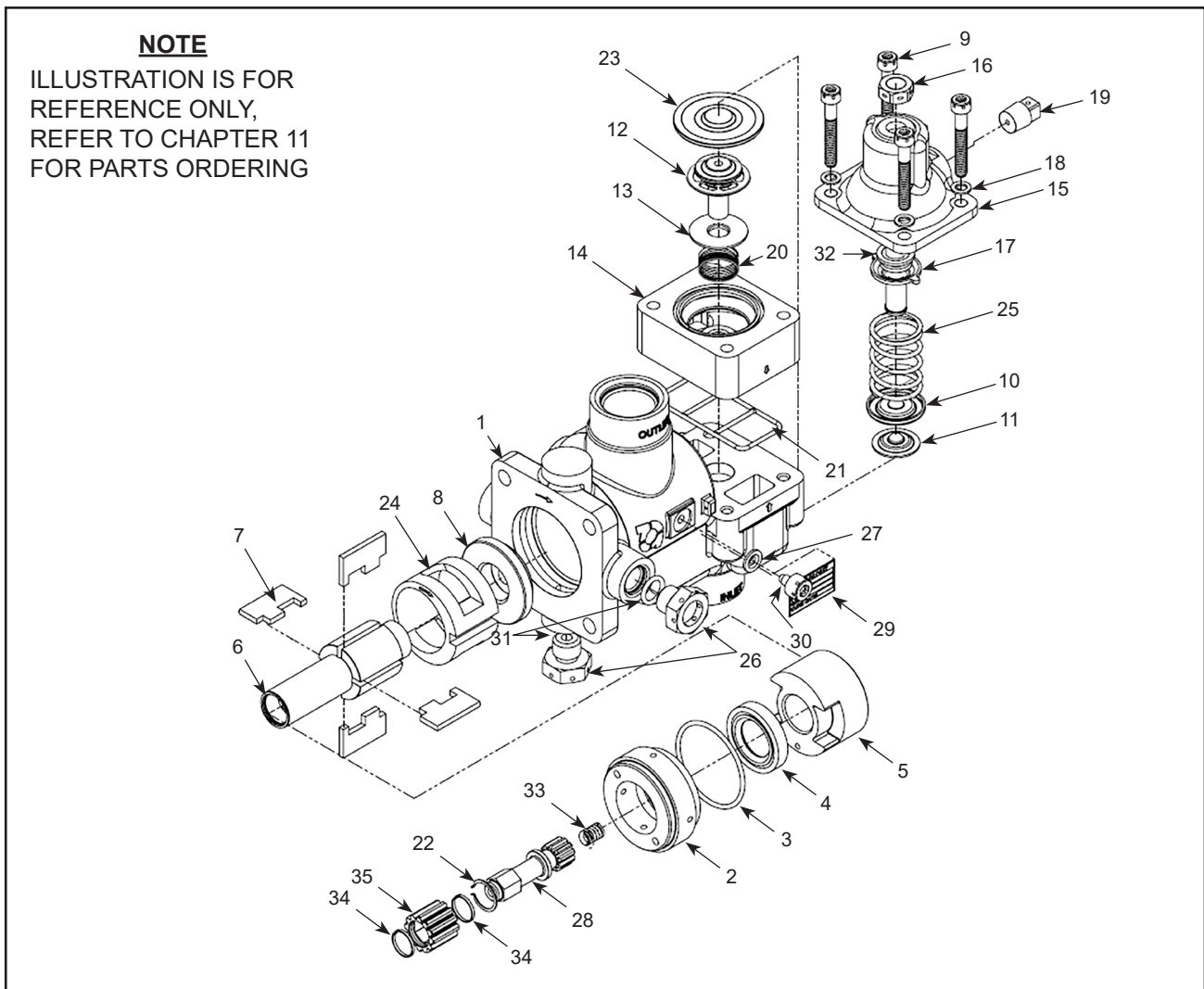
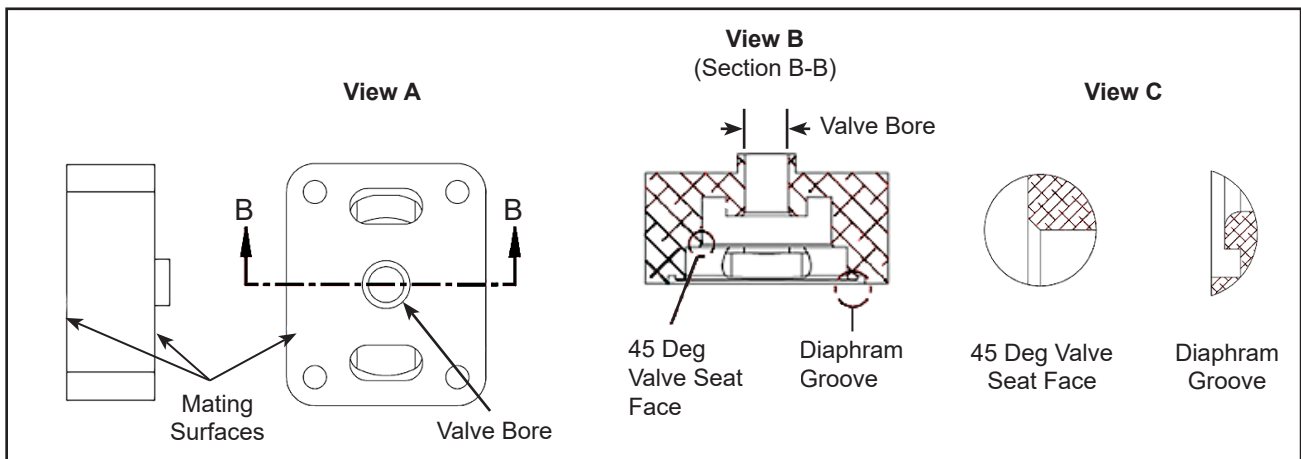

Figure 5-1 - 500F-0001, 500F-0002, & 500F-0004 Fuel Pump

Inspect	Serviceable Limits	Corrective Action
<b>Valve Housing (14)</b>		
(1) Using 3x magnification, visually examine the mating surfaces for nicks, burrs, and similar damage	A nick, burr, or similar damage on the mating surface may be repaired.	If there is a nick, burr or similar damage, repair or replace the valve housing. Refer to Repair section.
(2) Using 3X magnification, visually examine the valve gasket face for nicks, dings, and similar damage (Figure 5-2, View A).	A nick, ding, or similar damage is not permitted.	If there is a nick, ding or similar damage, replace the valve housing.
(3) Using 3X magnification, visually examine the diaphragm groove for nicks, dings, and similar damage (Figure 5-2, View B).	A nick, ding, or similar damage is not permitted.	If there is a nick, ding or similar damage, replace the valve housing.
(4) Using 3X magnification, visually examine the 45 ° face of the valve seat for grooves, or rounding (Figure 5-2, Views B and C).	A groove, or rounding of the 45 ° valve seat is not permitted.	If there is a groove or rounding, replace the valve housing.
(5) Using 3X magnification, visually examine the valve seat chamfer for scoring, nicks and similar damage (Figure 5-2, View B).	Scoring, nicks and similar damage may be repaired	If there is scoring, nicks or similar damage to the valve seat chamfer, refer to Repair section.
(6) Using 3X magnification, visually examine the walls of the valve bore for grooves, gouges, and similar damage (Figure 5-2, View A).	A groove, gouge, or similar damage in the valve bore may be repaired.	A groove, gouge, or similar damage in the valve bore may be repaired.
(7) Dimensionally examine the diameter of the valve bore (Figure 5-2, View B).	The maximum permitted diameter of the 500F fuel pump valve bore is 0.314 inch (7.98 mm).	If the diameter of the valve bore is greater than the permitted serviceable limit, replace the valve housing.

**Table 5-1 - Inspection Criteria** (cont'd →)



**Figure 5-2 - Valve Housing**

Inspect	Serviceable Limits	Corrective Action
<b>Rotor (6)</b>		
(1) Using 3X magnification, visually examine the entire outer surface of the rotor for chipping or galling.	The maximum permitted width of chipping or galling is 0.015 inch (0.38 mm).	If damage is greater than the permitted serviceable limits, replace the rotor.
(2) Using 3X magnification, visually examine the perimeter of the rotor head and the rotor face for indication of rubbing (Figure 5-3, detail D).	Indication of rubbing on the perimeter of the rotor head or rotor face is not permitted.	If rubbing on the perimeter of the rotor head or the rotor face is found, replace the rotor.
(3) Using 3X magnification, visually examine the snap ring groove for chips (Figure 5-3, View A).	No damage is permissible in the snap ring groove.	If chips in the snap ring groove are noted, replace the rotor.
(4) Dimensionally examine the snap ring groove diameter (Figure 5-3, View B).	The minimum permitted snap ring groove diameter is 0.542 inch (13.77 mm).	If the snap ring groove diameter is less than the permitted serviceable limits, replace the rotor.
(5) Dimensionally examine the rotor head diameter. (Figure 5-3, detail D).	The maximum permitted diameter is: 025F-0012: .856 inch 025F-0016: .935 inch	If the diameter of the rotor head is greater than the permitted serviceable limit, replace the rotor.
(6) Dimensionally examine both ends of the journal diameter (Figure 5-3, detail E).	The minimum permitted journal diameter is 0.6221 inch (15.801 mm). The maximum permitted journal diameter is 0.6223 inch (15.806 mm).	If the journal diameter is not within the permitted serviceable limits, replace the rotor.
(7) Measure the surface finish of the journal surfaces (Fig. 5-3, detail E).	The permitted minimum surface finish is 32Ra.	If the surface finish is greater than the permitted serviceable limits, repair as noted in the Repair section.
(8) Visually examine drive spline (Fig 5-3, detail C).	Polishing and light wear on pressure side of spline flanks is acceptable provided a machinist pick does not catch when lightly ran across flank. Wear on each flank should be similar in appearance. Pits, chips, spalling, or cracks are not acceptable.	If pits, chips, spalling, or cracks are observed, replace rotor.

(cont'd) **Table 5-1 - Inspection Criteria** (cont'd →)

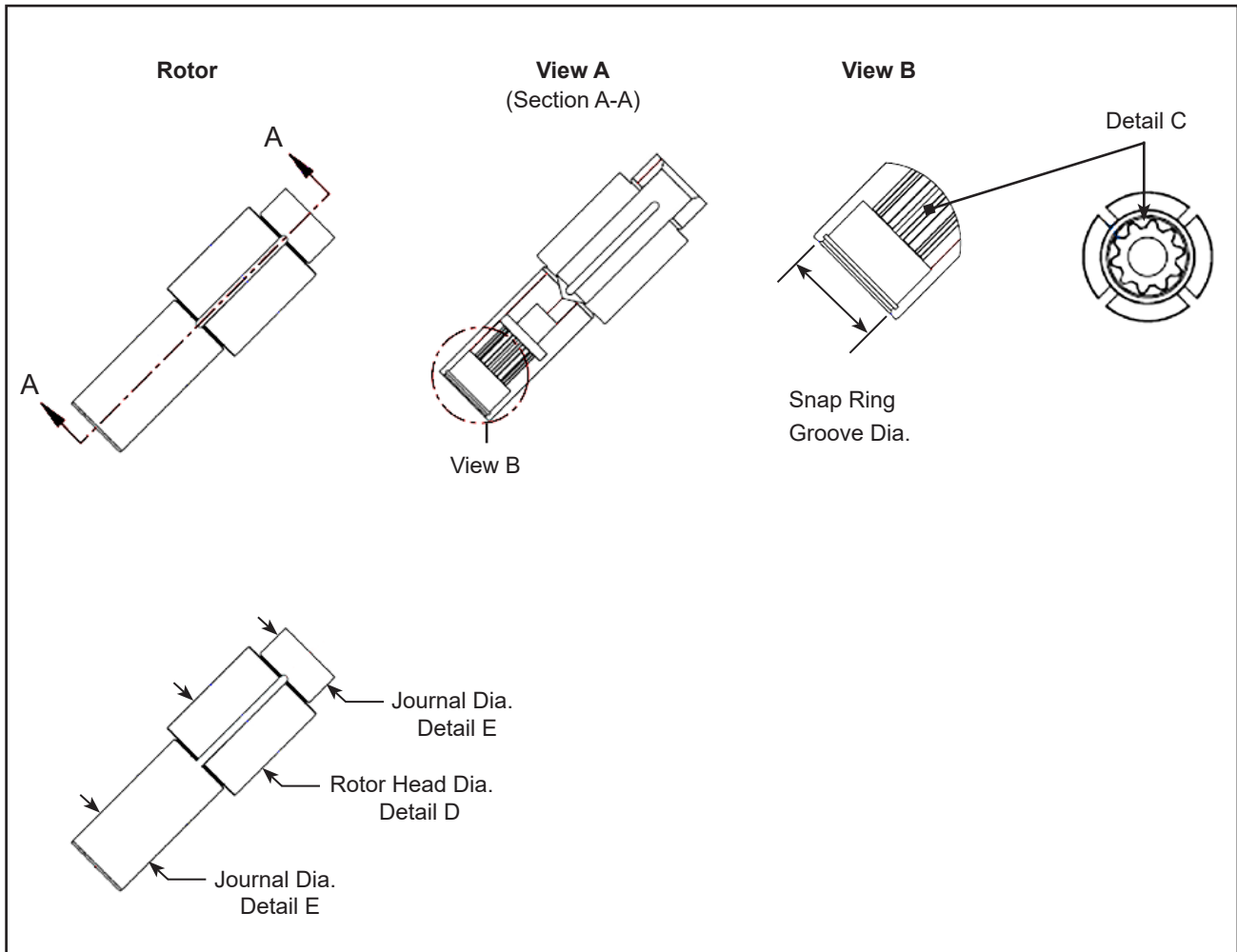

Figure 5-3 - Rotor

Inspect	Serviceable Limits	Corrective Action
<b>Drive Coupling Shaft (28)</b>		
(1) Visually examine shear section 3X (Fig 5-3a, detail A).	Light scratches that do not catch on a machinist pick. Gouges or cracks are not acceptable.	If machinist pick catches, replace coupling shaft. If gouges or cracks are present, replace coupling shaft.
(2) Dimensionally examine shear section (Fig 5-3a, detail A)	Minimum diameter .255 inch	If diameter is below minimum, replace coupling shaft.
(3) Visually examine coupling spline (Fig 5-3a, detail C).	Polishing and light wear on pressure side of spline flanks is acceptable provided a machinist pick does not catch when lightly ran across flank. Wear on each flank should be similar in appearance. Pits, chips, spalling, or cracks are not acceptable.	If a machinist pick catches replace rotor. If pits, chips, spalling, or cracks are observed, replace coupling shaft
(4) Visually examine drive end hex (Fig 5-3a, detail B).	Light scratches that do not catch on a machinist pick. Gouges or cracks are not acceptable.	If a machinist pick catches replace rotor. If pits, chips, spalling, or cracks are observed, replace coupling shaft.
(5) Dimensionally examine drive end hex (Fig 5-3, detail B).	Minimum dimension across hex (3X) is .3785	If width is below minimum, replace coupling shaft.
(6) Visually examine Shoulder (Fig 5-3a, detail A).	Light scratches that do not catch on a machinist pick. Gouges or cracks are not acceptable.	If a machinist pick catches replace rotor. If pits, chips, spalling, or cracks are observed, replace coupling shaft.
(7) Dimensionally examine shoulder OD (Fig 5-3a, detail C).	Minimum diameter .493 inch	If diameter is below minimum, replace coupling shaft.
<b>Compression Spring (33)</b>		
(1) Using a spring tester, record spring compression load (Fig 5-3a, detail D).	Spring rate: 23.5 lbs/in +/- 10%, Max load 7.25 lbs.	If spring compression load is not within serviceable limits, replace the spring.

(cont'd) Table 5-1 - Inspection Criteria (cont'd →)

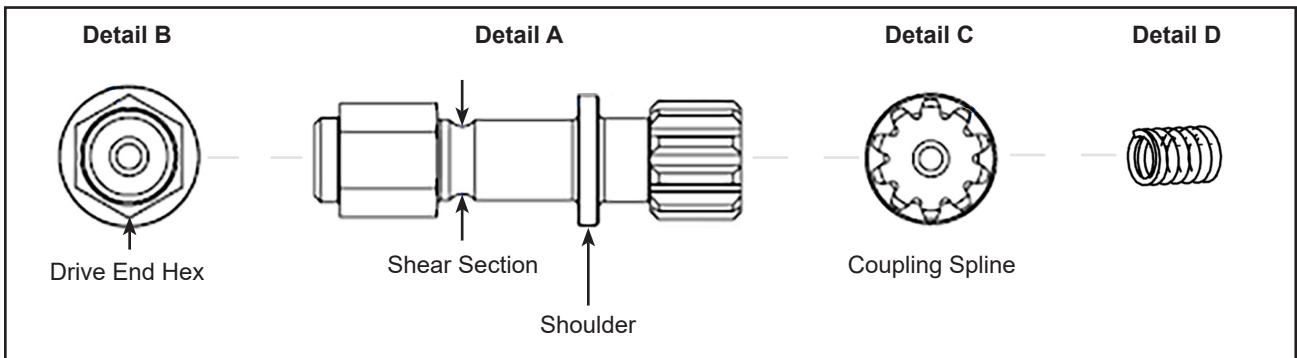
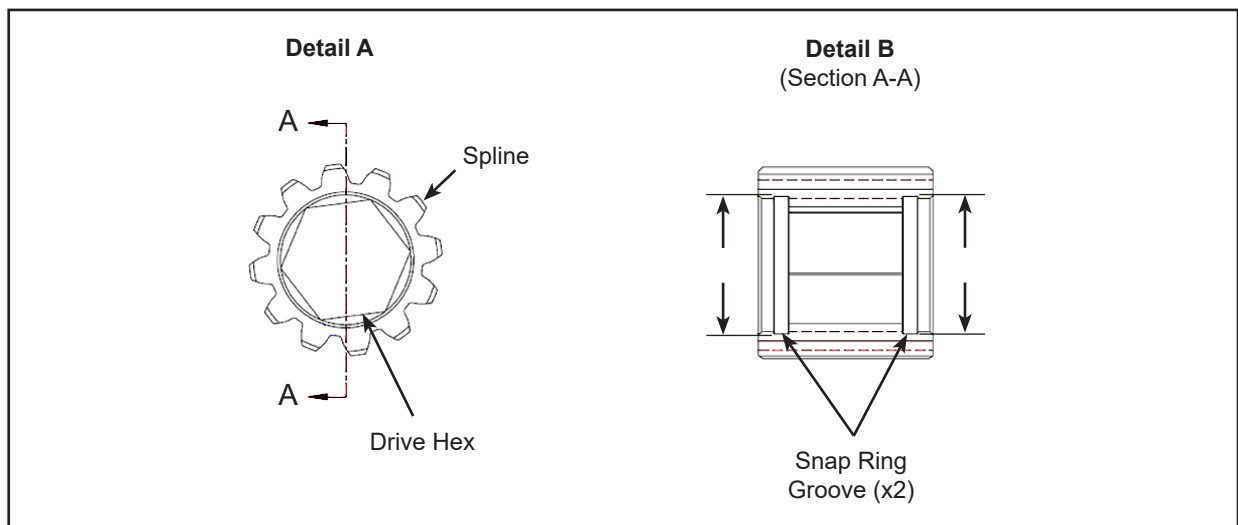

Figure 5-3a - Drive Coupling Shaft

Inspect	Serviceable Limits	Corrective Action
<b>Drive Coupling Sleeve (35)</b>		
(1) Visually examine drive hex (Fig 5-3b, detail C).	Light scratches that do not catch on a machinist pick. Gouges or cracks are not acceptable.	If a machinist pick catches replace rotor. If pits, chips, spalling, or cracks are observed, replace coupling sleeve.
(2) Dimensionally examine drive hex	Minimum dimension across hex (3X) is .3845 inch	If width is below minimum, replace coupling sleeve.
(3) Visually examine drive end hex (Fig 5-3, detail C).	Light scratches that do not catch on a machinist pick. Gouges or cracks are not acceptable.	If a machinist pick catches replace rotor. If pits, chips, spalling, or cracks are observed, replace coupling sleeve.
(4) Visually examine spline (Fig 5-3, detail C).	Polishing and light wear on pressure side of spline flanks is acceptable provided a machinist pick does not catch when lightly ran across flank. Wear on each flank should be similar in appearance. Pits, chips, spalling, or cracks are not acceptable.	If a machinist pick catches replace rotor. If pits, chips, spalling, or cracks are observed, replace coupling sleeve.
(5) Dimensionally examine snap ring grooves (2X) (Fig 5-3, detail B).	Maximum diameter: .459 inch	If diameter is below minimum, replace coupling sleeve.

(cont'd) **Table 5-1 - Inspection Criteria** (cont'd →)



**Figure 5-3b - Drive Coupling Sleeve**

Inspect	Serviceable Limits	Corrective Action
<b>Pump Housing (1)</b>		
(1) Visually and dimensionally examine the pump housing for pitting.	The maximum permitted depth of pitting is 0.250 inch (6.35 mm) or ten total defects that are a maximum of 0.025 inch (0.635 mm) within one square inch.	If damage is greater than the maximum permitted serviceable limits, replace the pump housing.
(2) Visually examine all threads for damage or wear.	Zero damage is permitted to 1 5/8-12 threads and O-Ring gland.	If any damage is found on the threads, replace the pump housing.
(3) Using 3X magnification, visually examine the bore diameter and surrounding flange for discontinuities (Figure 5-4, View B).	Minor discontinuities that can be blended out with an emery cloth are permitted.	Blend out minor discontinuities with an emery cloth. If discontinuities are greater than permitted serviceable limits, replace the pump housing.
(4) Perform an FPI inspection on the pump housing (Figure 5-4, View A) in accordance with instruction in the Inspection Requirements section of this chapter.	A crack in the pump housing is not permitted.	If there is a crack, replace the pump housing.

(cont'd) **Table 5-1 - Inspection Criteria** (cont'd →)

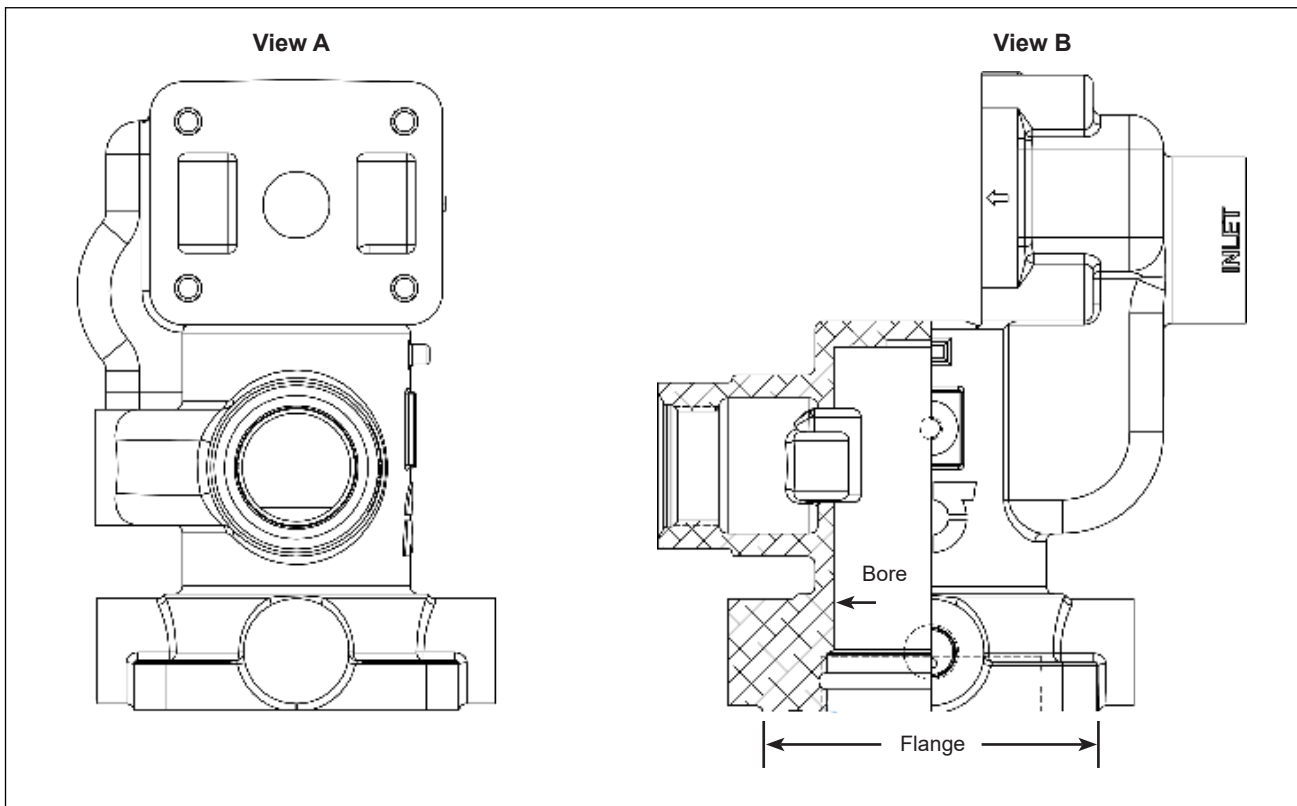

**Figure 5-4 - Pump Housing**

Inspect	Serviceable Limits	Corrective Action
<b>Pump Liner (24)</b>		
(1) Using 3X magnification, visually examine the inner surface of the pump liner for scratches, grooves, gouges and wear or rough surfaces (Figure 5-5).	Scratches, grooves, gouges, wear, or rough surface on the inner surface face of the pump liner are not permitted.	If scratches, grooves, gouges, wear, or a rough surface is observed, replace the pump liner. For balance of liner, refer to Repair, Chapter 6.
(2) Measure the surface finish of the inner pump liner surface. (Figure 5-5).	The permitted minimum surface finish is 16Ra.	If the surface finish is greater than the permitted serviceable limits, replace the pump liner.

(cont'd) **Table 5-1 - Inspection Criteria** (cont'd →)

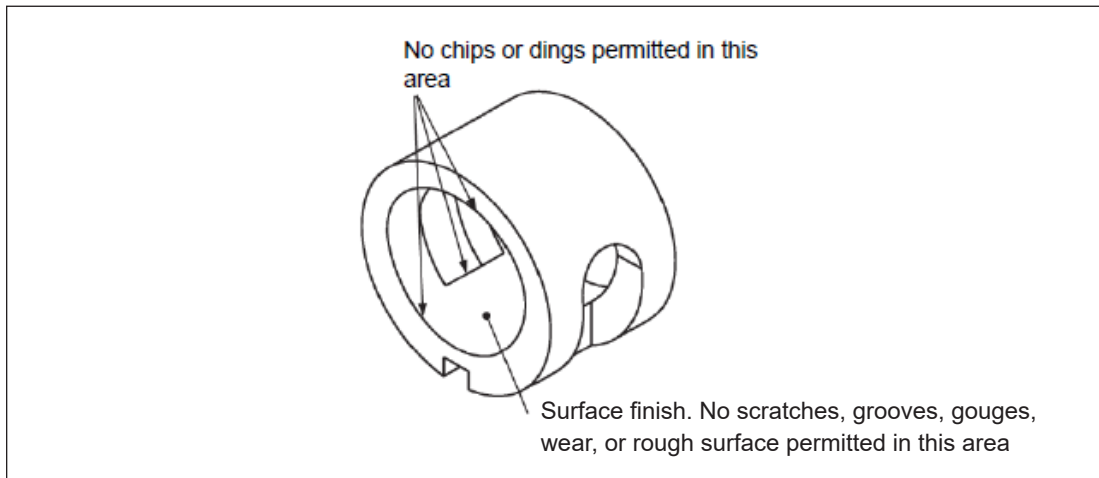

**Figure 5-5 - Pump Liner**

Inspect		Serviceable Limits	Corrective Action
<b>Bearing (5)</b>			
(1)	Using 3X magnification, visually examine the inner surface of the bearing for scratches, grooves, gouges and wear or rough surfaces (Figure 5-6, View A & B).	Chips, cracks or other damage are not permitted.	If damage is present, replace the bearing.
(2)	Using 3X magnification, visually examine the top face, bottom face, and bearing bore for grooves, cracks, and other wear or damage (Figure 5-6, View A & B).	Grooves, cracks, and other wear or damage are not permitted.	If damage is present, replace the bearing.
(3)	Measure the I.D. of the bearing bore at two locations (top and bottom) for roundness, taper, and wear (Figure 5-6, View A & B).	The maximum permitted ID of the bearing bore in any area is 0.6250 inch (15.88 mm).	If the ID of the bearing bore is greater than the permitted serviceable limits, replace the bearing.
(4)	Measure the thickness of the bearing at two locations. (Model 500F-0001 only, Figure 5-6 View A)	The minimum permitted thickness of the bearing is 0.874 inch (22.20 mm).	If the thickness of the bearing is less than the permitted serviceable limits, replace the bearing.
	Measure the thickness of the bearing at two locations. (Model 500F-0002 only, Figure 5-6, View B)	The minimum permitted thickness of the bearing is 0.771 inch (19.58 mm)	If the thickness of the bearing is less than the permitted serviceable limits, replace the bearing.

(cont'd) **Table 5-1 - Inspection Criteria** (cont'd →)

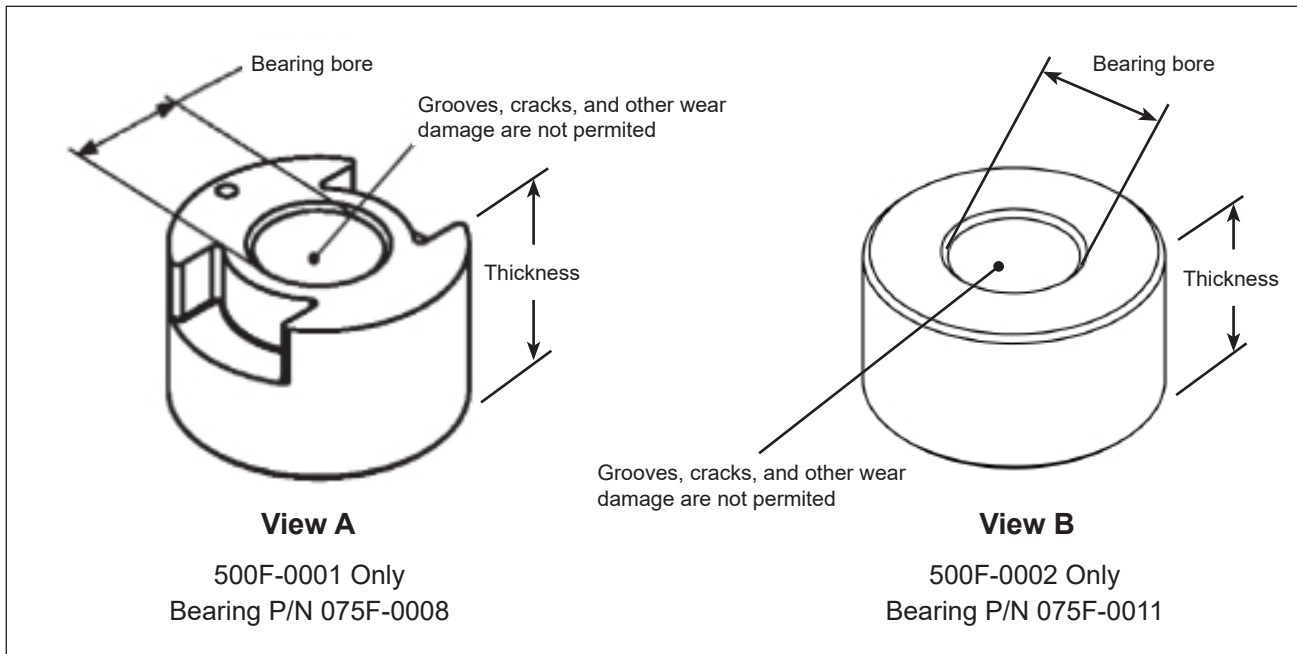

**Figure 5-6 - Bearing**

Inspect	Serviceable Limits	Corrective Action
<b>Bearing (8)</b>		
(1) Using 3X magnification, visually examine all bearing surfaces for chips, cracks, and damage (Figure 5-7).	Chips, cracks or other damage are not permitted.	If damage is present, replace the bearing.
(2) Using 3X magnification, visually examine the bottom surface and bearing bore for grooves, cracks, and other wear or damage (Figure 5-7, View B).	Grooves, cracks, and other wear or damage are not permitted.	If damage is present, replace the bearing.
(3) Measure the ID of the bearing bore at two locations for roundness, taper, and wear (Figure 5-7, View B).	The maximum permitted ID of the bearing bore in any area is 0.6250 inch (15.875).	If the ID of the bearing bore is greater than the permitted serviceable limits, replace the bearing.
(4) Measure the thickness of the bearing.	The minimum permitted thickness of the bearing is 0.310 inch (7.87 mm)	If thickness is less than the permitted serviceable limits, replace the bearing.

(cont'd) **Table 5-1 - Inspection Criteria** (cont'd →)

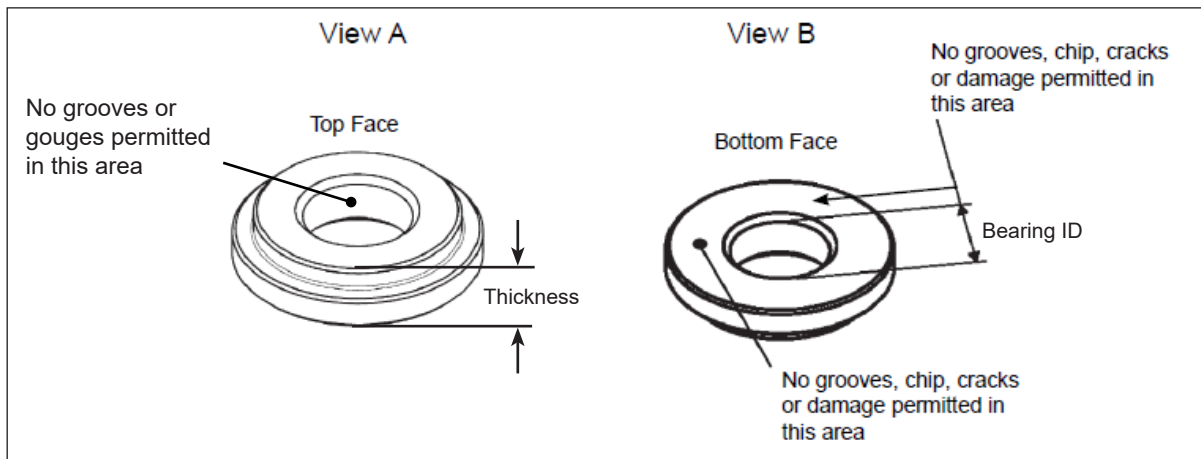

**Figure 5-7 - Bearing**

Inspect	Serviceable Limits	Corrective Action
<b>Diaphragm Plate (11)</b>		
(1) Using 3X magnification, visually examine the diaphragm plate for nicks, burrs, dings and similar damage (Figure 5-8).	Nicks, dings, burrs and other damage are not permitted.	If damage is present, replace the diaphragm plate.

(cont'd) Table 5-1 - Inspection Criteria (cont'd →)

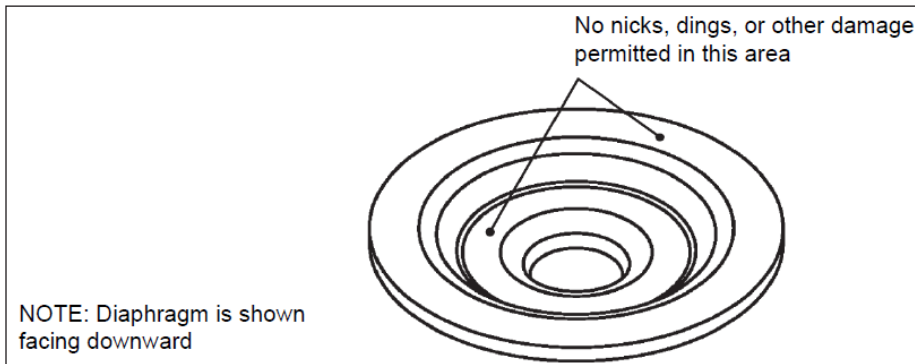

Figure 5-8 - Diaphragm Plate

Inspect	Serviceable Limits	Corrective Action
<b>Bypass Valve (13)</b>		
(1) Visually examine the top face of the bypass valve for grooves, cracks, and other wear or damage (Figure 5-9).	Nicks, dings, or similar damage to the top face of the bypass valve may be repaired.	If damage is present, repair or replace the bypass valve. Refer to Repair section.

(cont'd) Table 5-1 - Inspection Criteria (cont'd →)

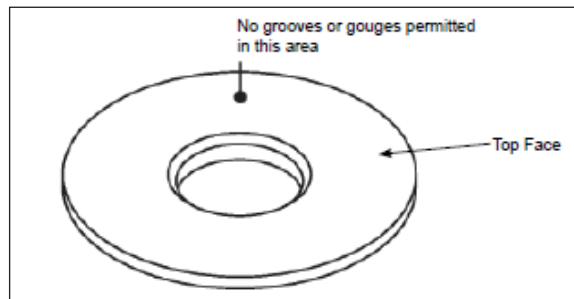
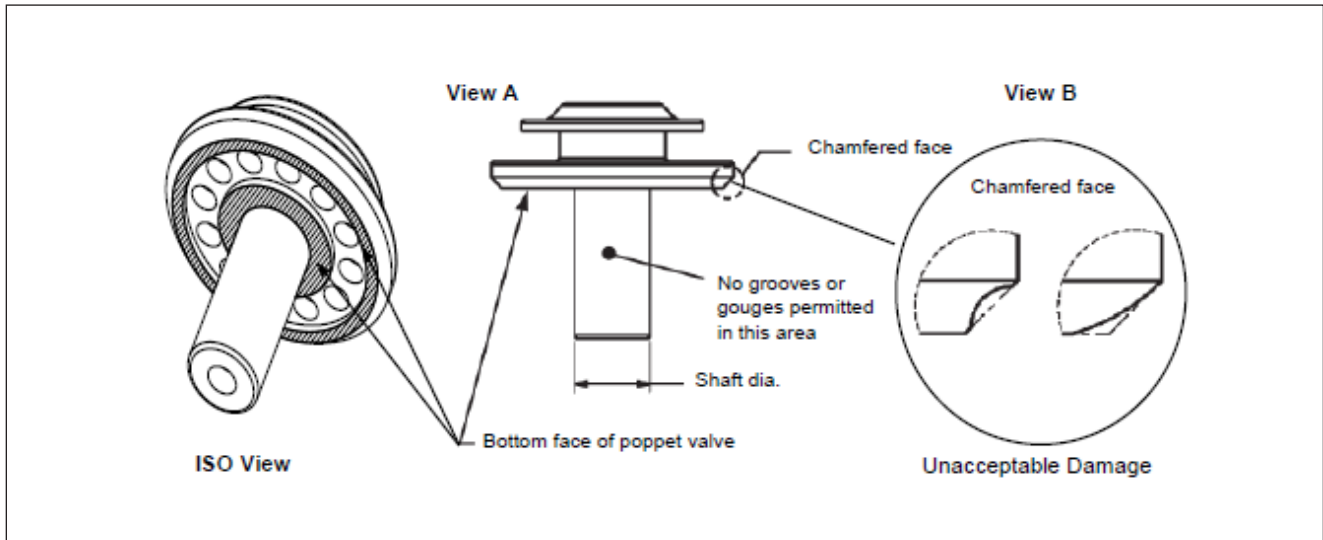

Figure 5-9 - Bypass Valve

Inspect	Serviceable Limits	Corrective Action
<b>Poppet Relief Valve (12)</b>		
(1) Using 3X magnification, visually examine the bottom face and shaft of the poppet relief valve for grooves, gouges, and other damage (Figure 5-10, View A).	Grooves, gouges, or similar damage to the bottom face of the poppet relief valve are not permitted.	If damage is present, replace the poppet relief valve.
(2) Using 3X magnification, visually examine the 45 degree chamfered face of the poppet relief valve for smooth, uniform surface (Figure 5-10, Views A and B).	The chamfered face of the poppet relief valve must be smooth and uniform	If damage is greater than the permitted serviceable limits, replace the poppet relief valve.
(3) Dimensionally examine the shaft diameter of the poppet relief valve (Figure 5-10, View A)	The minimum permitted shaft diameter is 0.3110 inch (7.90 mm)	If the shaft diameter is less than the permitted serviceable limits, replace the poppet relief valve.

(cont'd) **Table 5-1 - Inspection Criteria** (cont'd →)



**Figure 5-10 - Poppet Relief Valve**

Inspect	Serviceable Limits	Corrective Action
<b>Valve Cover (15)</b>		
(1) Using 3X magnification, visually examine the safety wire hole for cracks or tears (Figure 5-11).	Tears or cracks in the safety wire hole are not permitted.	If damage is present, replace the valve cover.
(2) Visually examine the threads for damage.	The maximum permitted thread damage is 1/3 of one thread or 10 percent of two threads total.	If thread damage is greater than the maximum permitted serviceable limits, replace the valve cover.

(cont'd) **Table 5-1 - Inspection Criteria** (cont'd →)

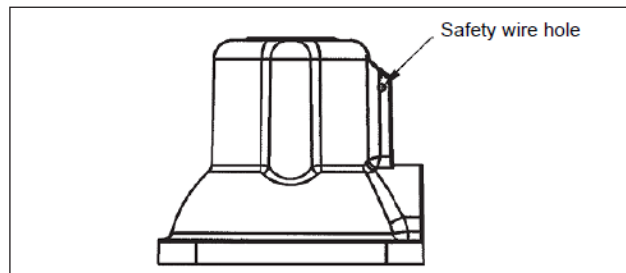

**Figure 5-11 - Valve Cover**

Inspect	Serviceable Limits	Corrective Action
<b>Set Screw (30)</b>		
(1) Using 3X magnification, visually examine the set screw for nicks, burrs, dings and similar damage.	Nicks, dings, burrs and other damage are not permitted.	If damage is present, replace the set screw.
<b>Plug (26)</b>		
(1) Using 3X magnification, visually examine the plug for nicks, burrs, dings and similar damage.	Nicks, dings, burrs and other damage are not permitted.	If damage is present, replace the plug.
<b>Adjusting Screw Assembly (17)</b>		
(1) Using 3X magnification, visually examine the adjusting screw assembly for nicks, burrs, dings and similar damage.	Nicks, dings, burrs and other damage are not permitted.	If damage is present, replace the adjusting screw assembly.
(2) Full movement of the adjusting screw Nut.	Nut must be able to be screwed full length of threaded portion.	If nut will not screw full length of threaded portion, replace adjusting screw assembly.

(cont'd) **Table 5-1 - Inspection Criteria** (cont'd →)



Inspect	Serviceable Limits	Corrective Action
<b>Spring Seat (10)</b>		
(1) Using 3X magnification, visually examine the spring seat for nicks, burrs, dings and similar damage.	Nicks, dings, burrs and other damage are not permitted.	If damage is present, replace the spring seat.
<b>Screw Cap (9) 4 ea.</b>		
(1) Using 3X magnification, visually examine the cap screw for nicks, burrs, dings and similar damage.	Nicks, dings, burrs and other damage are not permitted.	If damage is present, replace cap screw.
<b>Washer (18) 4 ea.</b>		
(1) Using 3X magnification, visually examine the washer for nicks, burrs, dings and similar damage.	Nicks, dings, burrs and other damage are not permitted.	If damage is present, replace washer.
<b>Relief Valve Spring (25)</b>		
(1) Using 3X magnification, visually examine the relief valve spring for nicks, burrs, dings and similar damage.	Nicks, dings, burrs and other damage are not permitted.	If damage is present, replace the relief valve spring.
(2) Using a spring tester, record spring compression load.	Permitted spring compression load: 10.8 lbs. ± 10 percent at .75 in.	If spring compression load is not within serviceable limits, replace the spring.
<b>Spring (20)</b>		
(1) Using 3X magnification, visually examine the spring for nicks, burrs, dings and similar damage.	Nicks, dings, burrs and other damage are not permitted.	If damage is present, replace the spring.
(2) Using a spring tester, record spring compression load.	Permitted spring compression load: .07 lbs. ± 20 percent at .250 in.	If spring compression load is not within serviceable limits, replace spring.
<b>Blade ( 7) 4 ea.</b>		
(1) Using 3X magnification, visually examine each blade for nicks, burrs, dings and similar damage (Figure 5-12).	Nicks, dings, burrs and other damage are not permitted.	If damage is present, replace affected and opposing blade (Detail C, Figure 5-11).
(2) Dimensionally examine the thickness of each blade. (Detail A, Figure 5-12)	The maximum permitted blade a) 055F-0005: .0716 inch (1.82 mm) b) 055F-0007 and 055F-0008: .935 inch (2.36 mm)	If blade thickness is greater than the permitted serviceable limit, replace affected and opposing blade.
	The minimum permitted blade a) 055F-0005 .0711 inch (1.81 mm) b) 055F-0007 and 055F-0008: .930 inch (2.36 mm)	If blade thickness is less than the permitted serviceable limit, replace affected and opposing blade.

(cont'd) Table 5-1 - Inspection Criteria (cont'd →)

Inspect	Serviceable Limits	Corrective Action
<b>Blade ( 7 ) 4 ea. - Continued</b>		
(3) Dimensionally examine the height of each blade (Detail B, Figure 5-12).	The maximum permitted blade height is: a) 055F-0005: 1.0381 inch (26.37 mm)  b) 055F-0007 and 055F-0008: .9375 inch (23.81 mm)	If blade height is greater than the permitted serviceable limit, replace affected and opposing blade.
	The minimum permitted blade is: a) 055F-0005: 1.0376 inch (26.36 mm)  b) 055F-0007 and 055F-0008: .9370 inch (23.80 mm)	If blade height is less than the permitted serviceable limit, replace blade pair as a set.
(4) Dimensionally examine the length of each blade pair (opposing blades, Detail C, Figure 5-12).	The minimum permitted length of blade pair is: a) 055F-0005: 1.0494 inch (26.65 mm)  b) 055F-0007: 1.0150 inch (25.87 mm)  c) 055F-0008: 1.0880 inch (27.64 mm)	If blade pair length is less than the permitted serviceable limit, replace blade pair as a set.

(cont'd) Table 5-1 - Inspection Criteria (cont'd →)

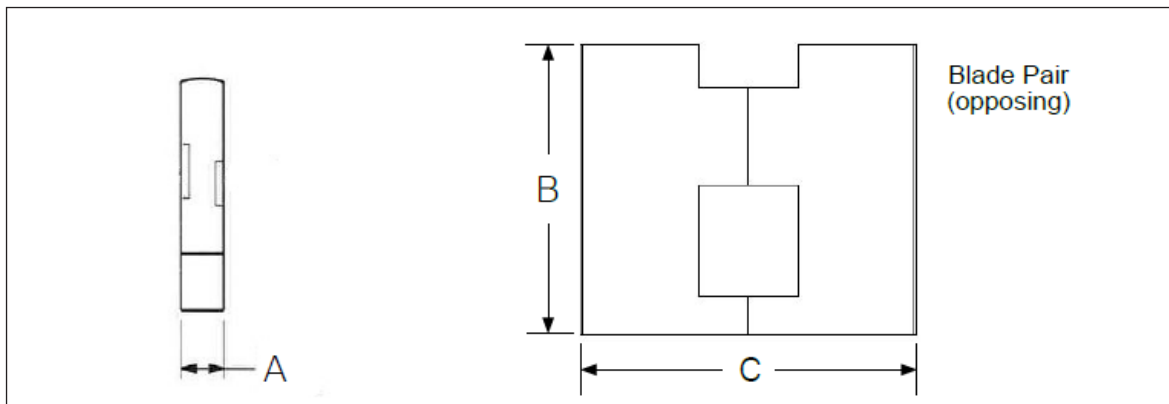
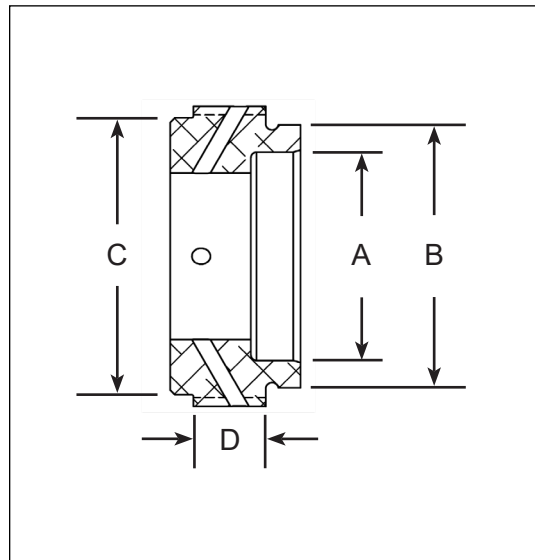

Figure 5-12 - Blade

Inspect	Serviceable Limits	Corrective Action
<b>Locknut (2)</b>		
(1) Using 3X magnification, visually examine the seal bore for pitting or scoring damage (Detail A, Figure 5-13).	Pitting and/or scoring is not permitted.	If damage is present, replace the locknut.
(2) Dimensionally examine the diameter of the seal bore. (Detail A, Figure 5-13).	The maximum permitted diameter of the seal bore is 1.126 inch (28.60 mm).	If the seal bore diameter is greater than the permitted serviceable limit, replace the locknut.
(3) Using 3X magnification, visually examine the locknut to bearing surface for pitting or scoring damage (Detail B, Figure 5-13).	Pitting and/or scoring is not permitted.	If damage is present, replace the locknut.
(4) Inspect concentricity of the locknut pilot (Detail C, Figure 5-13) to bearing pilot (Detail B, Figure 5-13).	The maximum out of concentricity is .005 for the locknut to bearing pilot.	If concentricity is not within tolerance, replace the locknut.
(5) Dimensionally examine the O.D. of the pilot (Detail C, Figure 5-13).	The minimum permitted O.D. of the pilot is .1494 inch (37.95 mm).	If the pilot O.D. is less than the permitted serviceable limit, replace the locknut.
(6) Using 3X magnification, visually examine the thread surface for nicks, burrs, dings, and similar damage (Detail D, Figure 5-13).	Nicks, dings, burrs, and other damage are not permitted.	If damage to the threads is present, replace the locknut.

(cont'd) **Table 5-1 - Inspection Criteria**



**Figure 5-13 - Locknut**

## 5.7 Special Inspections

### A. Misfueling Condition

- (1) Misfueling occurs when an incorrect grade of fuel is used to service an aircraft.
  - (a) If a misfueling event occurs, refer to the appropriate airframe and engine manuals for fueling practices.

### B. Sudden Engine Stoppage

- (1) If the aircraft or engine has experienced a “sudden stoppage” as defined by the engine manufacturer, the fuel pump may be critically impacted by this event. Although the fuel pump is designed with a “shear section” spline shaft, the design is for the seizure of the rotating components inside the pump and may not shear from the sudden stoppage of the engine drive train. The spline maybe weakened; however, setting up for a future failure under normal operating conditions. Upon authorization, the fuel pump may be returned to HET for evaluation.
- (2) If “sudden stoppage” as defined by the engine manufacturer has occurred, remove and inspect or replace the 500F fuel pump.
  - (a) Refer to the appropriate engine or airframe manuals to remove the 500F, fuel pump.
  - (b) Inspect 500F fuel pump in accordance with instructions in CHECK section, 5.3.B, 5.3.C, & 5.3.D of this manual as applicable. (Page 5-2).
  - (c) Drive coupling (22) replacement is required.

### C. Lightning Strike

- (1) If a report of a possible or actual lightning strike is made, inspect the aircraft for entry and exit points for the lightning bolt to confirm that there was a strike.
  - (a) The points of entry or exit are generally on the aircraft extremities such as the wing tip, propeller tips, spinner tip or the tips of tail surfaces.
  - (b) Commonly, the entry point is a single burn mark and the exit is several burn marks or burnt static wicks.
  - (c) Components using ferrous parts may become magnetized even if no damage is evident from a lightning strike.
    - 1) Check to see if fuel pump is magnetized by use of a Magnetic FieldIndicator (MFI) such as a Goodson no. CR-2480 or equivalent. The part is magnetic unless the MFI is reading zero.
    - 2) If magnetic, the pump must be demagnetized. Use of a Goodson no. SPD-46 demagnetizing table or other degaussing equipment is required. After degauss, check again with the MFI for a zero indication. (Refer to [www.goodson.com](http://www.goodson.com)).

---

Lightning Strike (cont'd)

- (2) If a strike is confirmed, remove the 500F fuel pump.
  - (a) Inspect the fuel pump mount and fittings for arc marks.
  - (b) Inspect the drive spline, as an arc here may leave raised metal which will cause further damage when the fuel pump is running.
  - (c) Visually inspect the mounting flange for damage.
    - 1) If there is any damage, overhaul or replace the fuel pump.
    - 2) Use the appropriate airframe and engine manufacturers' maintenance or service instructions to accomplish this task.
  - (d) If there are no indications of arc marks or damage, reinstall the fuel pump.
    - 1) Do a leak check in accordance with the appropriate airframe and engine manufacturers' maintenance or service instructions.
  - (e) Test run the engine per the POH or AFM before returning the aircraft to service.
  - (f) Make a logbook entry regarding the lightning strike and remedy.

## Chapter 6 - Repair

### 6.1 General

- A. Repairs to 500F Series fuel pumps are limited to those that are necessary to maintain the serviceable limits and dimensional tolerances specified in the Check chapter of this manual.
- B. Minor surface irregularities may be blended if resurfacing procedures do not alter the dimensional specifications for the part.
- C. Machined mating surfaces may be lightly dressed using polishing paper or 1000 grit wet/dry paper on a flat surface plate.

### 6.2 Aluminum Parts

- A. Anodize
  - (1) The fuel pump housing (1) is anodized at the factory. The anodized surface may be black or clear.
  - (2) It is not necessary to strip the anodize before penetrant inspection is performed.
- B. Alodine®
  - (1) Bare aluminum surfaces (pump body and relief valve housing) that are exposed by surface preparation must be treated with Alodine® (or equivalent non-anodic protective coating) to prevent corrosion.
  - (2) Alodine® treatment of the fuel pump housing (1) is limited to a localized areas and are intended for exterior protection.
  - (3) Do not immerse the fuel pump housing in Alodine® solutions. See Mil-C-5541 or SAE AMS-C-5541 for Alodine specifications.

### 6.3 Steel and Stainless Steel Parts

- A. The liner and rotor may be polished with a cloth buffing wheel or crocus cloth.
- B. Make sure not to break or round sharp edges when polishing these parts.
- C. Use an oil stone or crocus cloth to remove any scoring, small nicks or raised areas.
  - (1) These procedures must not alter dimensional specifications for the part specified in Table 5-1 of the Checks chapter of this manual.
- D. When polishing is completed, protect the repaired part with preserving oil.

### 6.4 Specific Repairs

- A. Poppet Stem Bore in Relief Valve Housing (14)
  - (1) Grooves and scratches in the poppet stem bore in the relief valve housing no deeper than 0.015 in width or depth are permitted only if high material areas can be successfully removed using conventional honing techniques.

- (2) Tolerances specified in the Check Chapter and the Fits and Clearances chapter and of this manual must be maintained.

B. Relief Valve Housing, Bypass Valve and Seat Repair

- (1) Use 600-1000 grit silicon carbide grease (or equivalent lapping compound) refinish the mating surfaces of the relief valve housing (14), bypass valve (13) and poppet relief valve (12).

**NOTE:** Clover Lapping Compound may be purchased from Loctite® ([www.loctite.com](http://www.loctite.com)) in 4 ounce cans 600 grit or 1000 grit.

- (2) Relief Valve Housing Seat Repair

- (a) Evenly coat the chamfered seating area of the relief valve housing with a thin film of this paste-type lapping compound and insert the poppet relief valve (12) into the bore of the relief valve housing (14).
- (b) Lap the poppet relief valve to the seat using very light pressure, occasionally lifting the valve to reorient it to the seat.
- (c) Continue lapping until the two mating surfaces are uniformly seated.

- (3) Bypass Valve Repair

- (a) Evenly coat the bypass valve seating area of the relief valve with a thin film of this paste-type lapping compound and slide the bypass valve (13) over the shaft of the relief valve (12).
- (b) Continue lapping until the two mating surfaces are uniformly seated.

**WARNING:** CLEANING AGENTS (ACETONE, #700 LACQUER THINNER, AND MEK), ARE FLAMMABLE AND TOXIC TO THE SKIN, EYES, AND RESPIRATORY TRACT. SKIN AND EYE PROTECTION ARE REQUIRED. AVOID PROLONGED CONTACT. USE IN A WELL VENTILATED AREA.

- (4) Thoroughly clean the poppet relief valve (12), bypass valve (13), and relief valve housing (1) with Methyl Ethyl Ketone (MEK) or equivalent rapidly evaporating solvent, to remove all residual traces of lapping compound.
- (5) If the tolerances specified in the Check Chapter and the Fits and Clearances chapter and of this manual cannot be maintained, replace the part.

C. Relief Valve Housing Mating Surface

- (1) Burrs in the relief valve housing mating surfaces may be removed using a very fine grade of polishing paper or crocus cloth.
- (2) Make sure not to break or round sharp edges when removing burrs.

## Chapter 7 - Assembly

### 7.1 General

**CAUTION:** ASSEMBLY, CLEANING, AND INSPECTION MUST BE PERFORMED IN A CLEAN ENVIRONMENT, FREE OF EXCESSIVE DUST, MOISTURE, OR CONTAMINANTS. ANY SMALL PARTICLE(S) TRAPPED BETWEEN THE RELIEF VALVE POPPET AND SEAT CAN CREATE A LOSS OF PRESSURE AT LOW RPM AND COULD RESULT IN IRREPARABLE DAMAGE TO THE SEATING AREA.

- A. Assembly, cleaning, and inspection must be performed in a clean environment, free of excessive dust, moisture, or contaminants.
- B. Always refer to the instructions in this manual before performing any repairs, overhauls, or testing of a fuel pump.
  - (1) The information in this section applies to FAA/PMA approved 500F fuel pumps.
- C. Use of Illustrated Parts List (IPL)
  - (1) Illustrations in this chapter are for assembly reference only. Refer to Chapter 11 for ordering of parts.
- D. Identification Tag Replacement
  - (1) When performing a field overhaul or repair, replacement of the data tag (nameplate) with a new data tag stamped with the performing facility information and repair station number, as well as all other applicable data on the existing data tag is required.
    - (a) The nameplate must be stamped with the words "Field-Overhauled".
    - (b) Blank nameplates are available from HET but must be filled out properly.
    - (c) The nameplate may be locally manufactured but must be approved by your local civil aviation authority before the fuel pump is returned to service.
- E. Lightly lubricate O-rings with Chemplex® 710 or Parker O-lube ([www.parker.com](http://www.parker.com)), or other suitable O-ring or packing lubricant to help in installation and to reduce the risk of damage to these parts.

### 7.2 Assembly of the FAA/PMA 500F Series Fuel Pump

- A. General
  - (1) The following Assembly procedures are applicable to all 500F fuel pumps.
  - (2) Refer to Figure 7-1 for an exploded view of the fuel pump.

**CAUTION:** THE PARTS SHOULD FIT FREELY INTO THE BORE OF THE PUMP HOUSING WHEN PROPERLY ALIGNED. SMALL CHIPS, BURRS OR SCRATCHES DUE TO MISHANDLING MAY CREATE DIFFICULTIES IN ASSEMBLY.

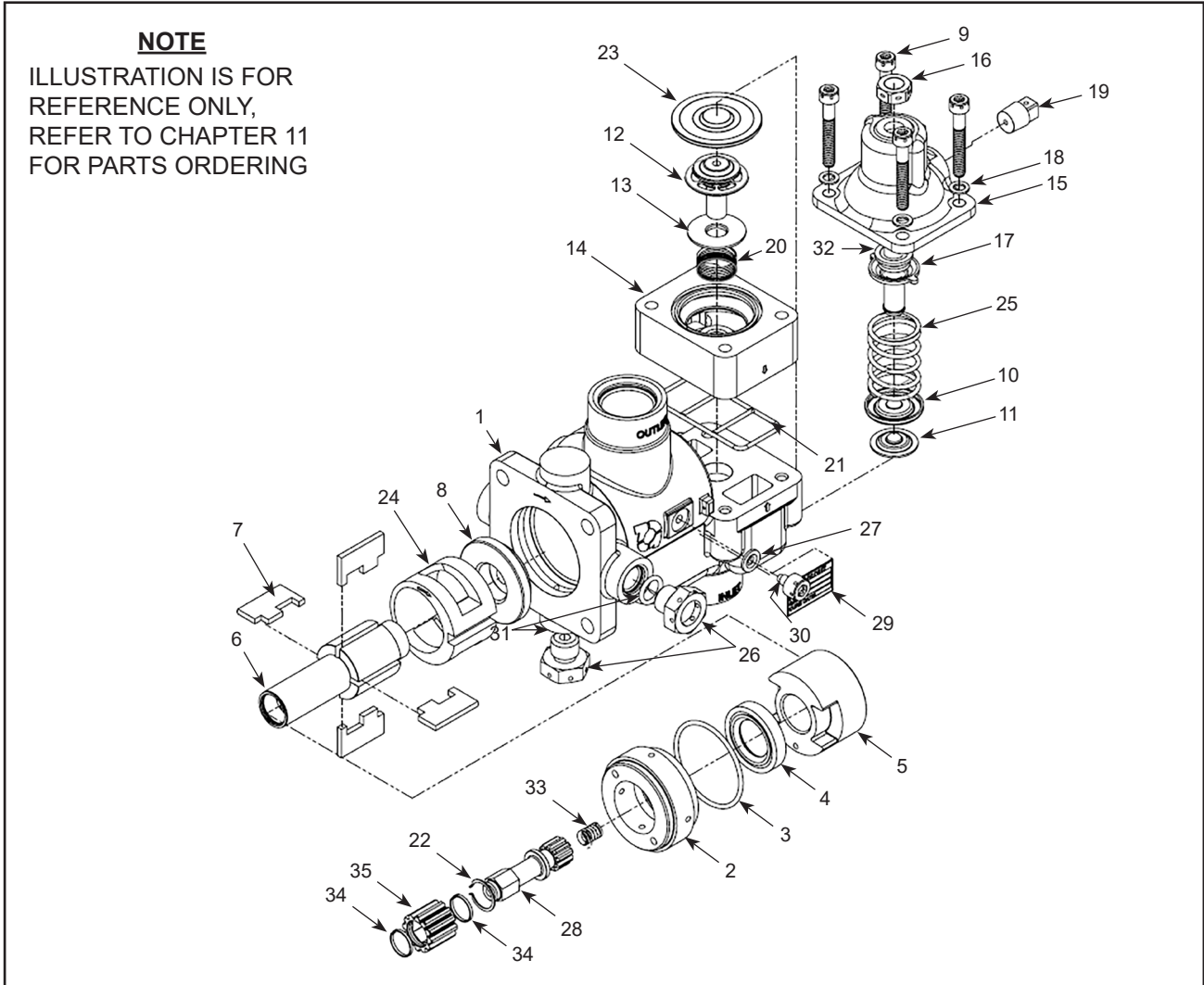
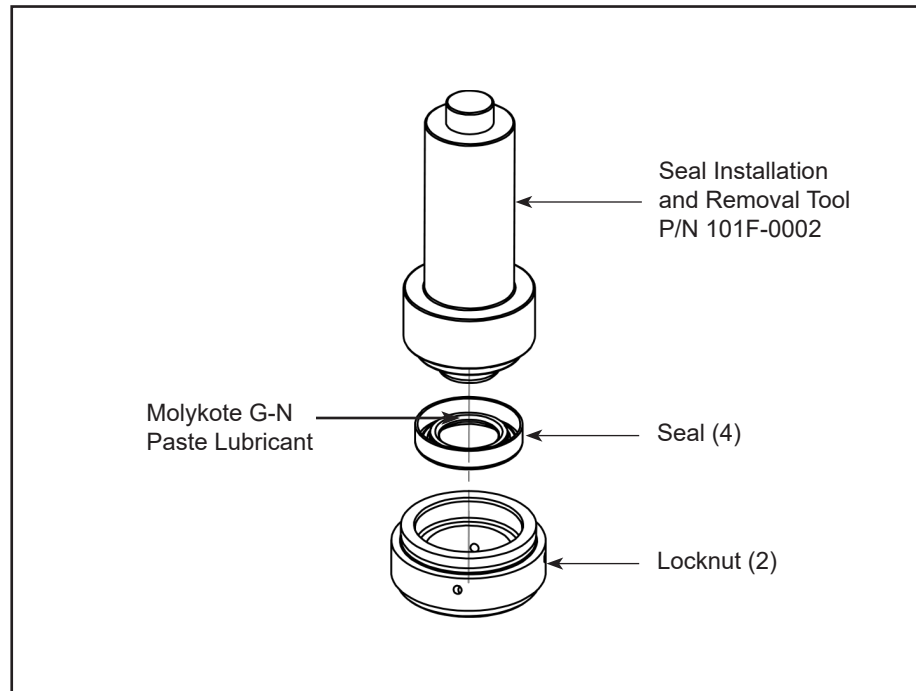

**Figure 7-1 - 500F-0001, 500F-0002, & 500F-0004 Fuel Pump**

1. Housing, Fuel Pump	10. Seat, Spring	19. Plug	28. Drive Coupling
2. Locknut	11. Plate, Diaphragm	20. Spring	29. Data Tag
3. Packing	12. Poppet	21. Gasket, Valve	30. Screw
4. Seal	13. Valve, Bypass	22. Ring, Retaining	31. Packing
5. Bearing	14. Housing, Valve	23. Diaphragm	32. O-Ring Washer Assy
6. Rotor	15. Cover, Valve	24. Liner	33. Spring, Compression
7. Blade, Pump	16. Nut, Jam	25. Spring	34. Ring, Retaining
8. Bearing	17. Screw, Adj. Assy.	26. Plug, Port	35. Sleeve, Coupling
9. Screw, Cap	18. Washer	27. Packing	

B. Seal Installation

- (1) Place the locknut (2) in an appropriate fixture with the spanner side facing down.
- (2) Apply Loctite® primer #7471 or #7649 to the outside diameter of the seal (4) and allow to dry.
- (3) Position the seal (4) with the lip facing upwards.
- (4) Place the pump shaft seal (4) on the small end of the Seal Installation and Removal Tool P/N 101F-0002.
- (5) Apply a light coat of adhesive Loctite® #609 to the outside diameter of the seal (4).
- (6) Press and fully seat the seal (4) into its bottomed position in the locknut (2) seal bore. Refer to Figure 7-2.
- (7) Using a cotton swab soaked in MEK, wipe off any excess Loctite® from the bottom of the bore.
- (8) Apply a thin coat of Molykote G-N paste lubricant to the ID of the seal (4) where the rotor (6) will contact.



**Figure 7-2 - Seal Installation**

C. Pump Housing Assembly

- (1) Place the pump housing (1) in appropriate fixture with drive end pointing upward.
- (2) Install bearing (8) into the pump housing; largest surface facing up. Refer to Figure 7-3.
- (3) Carefully seat the bearing (8) into its final bottomed position within the housing.

**CAUTION:** THE PUMP BLADES (7) MAY BE DAMAGED IF DROPPED OR HIT AGAINST OTHER COMPONENTS. CARE SHOULD BE TAKEN WHILE HANDLING THE PUMP BLADES (7) DURING MAINTENANCE.

- (4) Fit the four blades (7) into the slots in the rotor (6). Refer to Figure 7-4.
  - (a) Position blade A and blade D with the narrow tab facing toward the top of the rotor.
  - (b) Position blade B and blade C with the wide tab facing toward the top of the rotor.

**NOTE:** If blades do not slide easily in and out of the slots in the rotor, replace the blades.

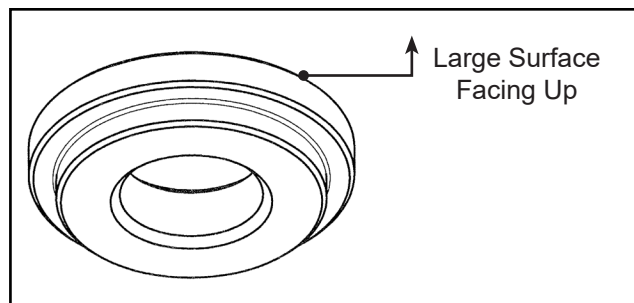

Figure 7-3 - Bearing

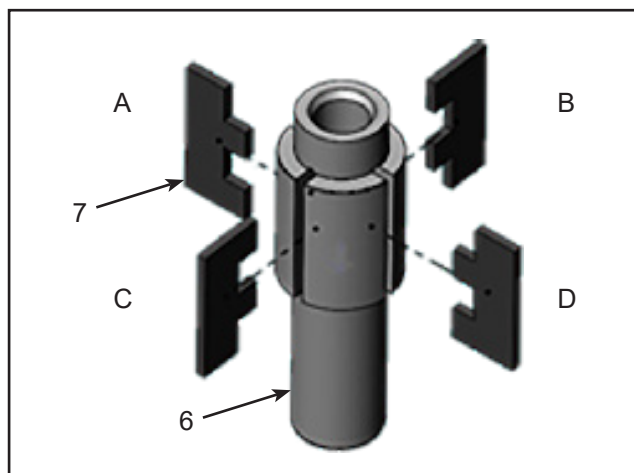
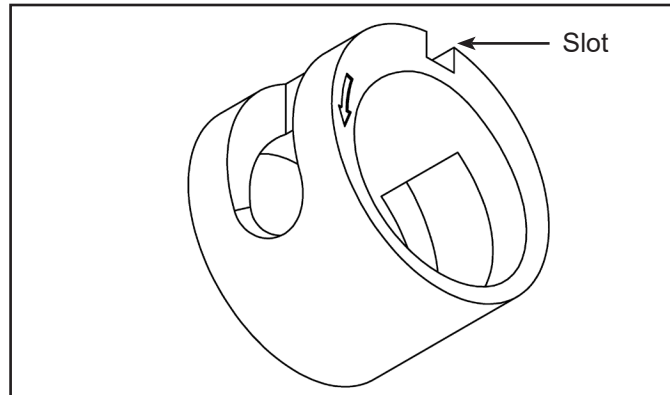

Figure 7-4 - Rotor and Blades

- (5) Place the bearing (5) onto rotor (6) (Figure 7-4). Stepped end of bearing must point upward.
- (6) Place the pump liner (24) over the rotor (6) and blades (7) until it is seated against bearing (5).
- (7) Install the rotor with blades (6), bearing (5), and pump liner (24) into the fuel pump housing (1).
- (8) Carefully remove the bearing (5) to expose the liner (24), rotor (6), and vanes (7).
- (9) Rotate the liner (24) until the slot (Figure 7-5) is aligned with the bore of the anti-rotation screw (30).
- (10) Install the packing and retainer (27) onto the set screw (30). The packing and retainer (27) consists of a washer and O-ring.
  - (a) Lightly coat the O-ring with Chemplex® 710 or an equivalent dielectric silicone lubricant.
  - (b) Install the O-ring on the set screw.
  - (c) Install the washer over the O-ring.
  - (d) Thread the set screw (30) into the pump housing (1) at the location indicated in Figure 7-1.
  - (e) Torque the set screw (30) to 10-12 in-lbs (1.13-1.35 Nm). Do not safety wire at this time.
- (11) Check clearances of rotor (6), pump liner (24), and blades (7).
  - (a) Rotor-to-pump liner rotating clearance must be established by the following methods:
    - 1) Visual inspection
    - 2) Feeler gage Inspection
    - 3) Touch
    - 4) Torque gage
  - (b) Using 10X magnification, visually inspect for contact between the rotor (6) and the pump liner (24) at the closest points of contact.
    - 1) If contact is visible, replace the rotor (6) or pump liner (24).
    - 2) Repeat inspection as needed until contact is not visible.
  - (c) Using a 0.0015 feeler gage, place the gage through the points of closest contact between the rotor (6) and blades (7) and the pump liner (24).
    - 1) The gage is permitted to be snug when pulled through, but must not snag or stick.
  - (d) Slowly rotate the rotor (6) and check for contact or interference.
    - 1) If the rotor (6) does not rotate freely, replace the rotor (6), blades (7), or pump liner (24).
    - 2) Repeat as needed until the rotor rotates freely.



**Figure 7-5 - Liner**

- (12) Install the bearing (5) with slots facing up.
- (13) Lightly coat the packing (3) and seal lip (4) with Chemplex® 710 or an equivalent dielectric silicone lubricant.
- (14) Install packing (3) onto locknut (2).
- (15) Apply Loctite primer to the threads of the locknut (2) and pump housing (1) and allow to dry for 24 hours.
- (16) Apply Loctite RC/609 to the lower portion of the locknut (2) threads.
- (17) Apply a thin film of Molykote G-N paste to rotor shaft where the seal (4) will contact.
- (18) Install seal guide P/N 101F-0001 onto the end of the rotor (6) to cover the slot.
- (19) Using a spanner wrench (pin size: 1/8 in., 2.9 mm), thread the locknut (2) into the pump housing (1) and tighten until fully seated.
- (20) Carefully remove the seal guide and verify no damage to the rotor end.
- (21) Turn the rotor (6) by hand to make sure there is no binding of the blades (7) and that the rotor turns freely.
- (22) Check torque required to rotate rotor
  - (a) The rotor torque must not be greater than 17 inch-ounce.
  - (b) If the torque is greater than 17 inch-ounce, replace the rotor (6) or pump liner (24).
  - (c) Repeat as needed until torque is within the specified limits.

D. Assembly of the Fuel Pump Relief and Bypass Valve

**CAUTION:** DO NOT APPLY ANY FORM OF LUBRICANT, SEALANT, OR COMPOUND DIRECTLY TO THE MATING SURFACES OF THE PUMP HOUSING, VALVE HOUSING, OR VALVE COVER. THESE MATING SURFACES MUST REMAIN FREE FROM CONTAMINATION.

- (1) Lightly coat the gasket (21) with Chemplex® 710 or an equivalent dielectric silicone lubricant.
- (2) Place the gasket (21) into the cavity machined in the valve housing (14).
- (3) Place the valve housing with the gasket installed on the mounting pad area of the pump housing.
  - (a) Ensure the index marks on the valve housing (14) and the pump housing (1) are as shown in Figure 7-6. Arrows must be pointed toward each other on the same side, but do not necessarily need to be perfectly aligned.

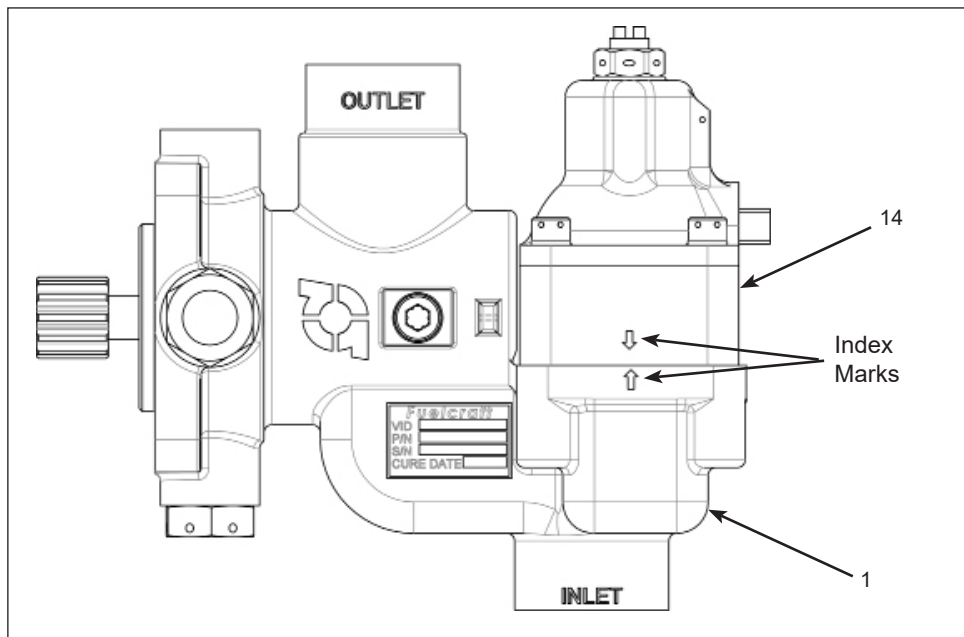

Figure 7-6 - Valve Housing Alignment

*For clarification purpose, refer to Figure 7-7 for steps 4 thru 14.*

- (4) Install spring (20) into the relief valve housing.
- (5) With the flat side the bypass valve (13) facing the poppet relief valve (12), install the bypass valve (13) onto the stem of the poppet relief valve (12).
- (6) Install the assembled bypass valve (13) and poppet relief valve (12) into the relief valve housing. Verify that poppet moves freely.
- (7) Apply a thin film of Chemplex 710, or equivalent, covering the entire surface of each side of the diaphragm (23) and install the diaphragm into the relief valve housing.

**NOTE:** Ensure the outer bead of the diaphragm is uniformly engaged in the recessed groove of the valve housing.

- (8) Place the concave side of diaphragm plate (11) against the center of the diaphragm (23).
- (9) Place the spring seat (10) on top of the diaphragm plate with the cupped lip pointing towards the relief valve cover.
- (10) Place the spring (25) in the cupped portion of the spring seat (10).
- (11) Lubricate the O-ring assembly (32) with Chemplex® 710 or an equivalent dielectric silicone lubricant and install the O-ring assembly over the slotted end of the adjusting screw (17) until it mates against the shoulder of the adjusting screw (17).

**CAUTION:** TAKE CARE NOT TO NICK THE O-RING ON THE SET SCREW ADJUSTMENT SLOT DURING O-RING INSTALLATION.

- (12) Insert the slotted end of the adjusting screw (17) through the valve cover (15).
- (13) Turn the adjustment screw (17) fully counter-clockwise to prevent pre-loading the relief valve poppet while securing the valve cover (15) to the pump housing (1).
- (14) Thread the jam-nut (16) onto the adjusting screw (17) and tighten until finger tight.

**NOTE:** Final adjustments will be made during testing and calibration.

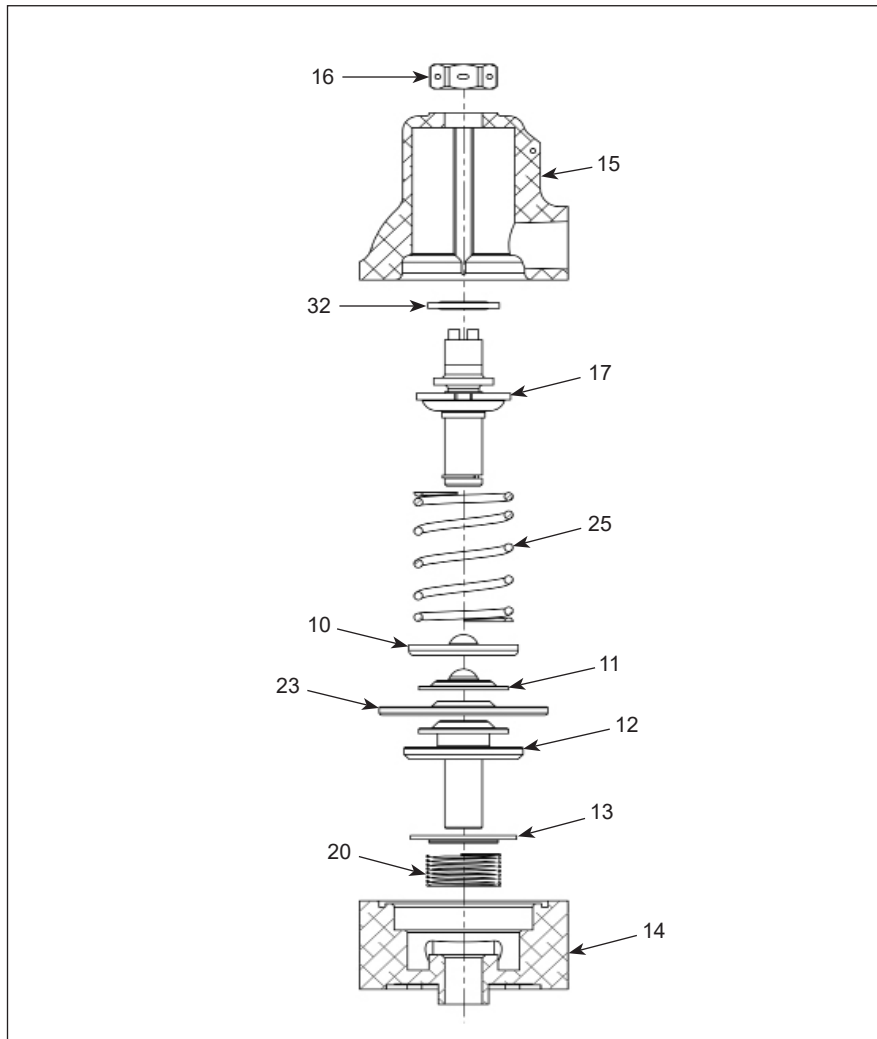

Figure 7-7 - Valve Housing Component Arrangement

- (15) Place the valve cover (15) onto the valve housing (14).
- (16) Using four screws (9) and washers (18), attach the assembled valve cover.
- (17) Using a crisscross pattern, progressively torque the four cover screws (9) 23-25 in-lbs (2.59-2.82 Nm).

**NOTE:** A gradual, incremental, drawing down of the screws will reduce the risk of overstressing or distorting any parts.

- (18) Using a 0.0015 feeler gage, check for a gap between the valve housing (14) and the pump housing (1).
  - (a) If a gap greater than 0.0015 is found, re-torque the cap screws (9).
  - (b) Repeat the inspection.
  - (c) If a gap greater than 0.0015 is found, remove the valve housing (14) and verify that the gasket is seated correctly. Replace gasket if damaged.
- (19) Apply a coating of grease (MIL-G-23827) to the internal splines of the rotor shaft (6) and the external splines of the drive coupling assembly (28) and insert the drive coupling assembly into the rotor.
- (20) Install the retaining ring (22) with the tabs (Figures 7-8 & 7-9) pointing away from the pump housing (1) to hold the drive coupling assembly (28) to the rotor shaft (6).
  - (a) Make sure the retaining ring (22) is fully seated within the shaft retaining ring groove. Gently pull on the coupling (28) to ensure snap ring engagement and coupling retention.

#### E. Pipe Plug Installation

- (1) Install pipe plug (19) and port plugs (26) in the fuel pump housing.
  - (a) Lightly coat new packings (31) with Chemplex® 710 or an equivalent dielectric silicone lubricant and install packings onto port plugs (26).
  - (b) Apply Loctite® 565 or equivalent thread sealant to the threads of pipe plug (19) and port plugs (26) prior installation.
  - (c) Torque pipe plug (19) and port plugs (26) in accordance with Table 8-1 - *Torque Values*.

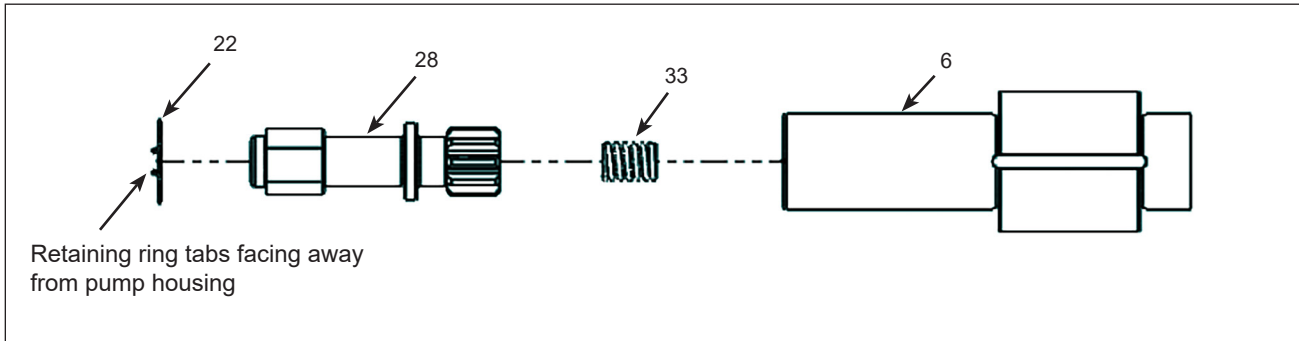

**Figure 7-8 - Drive Coupling Assembly**

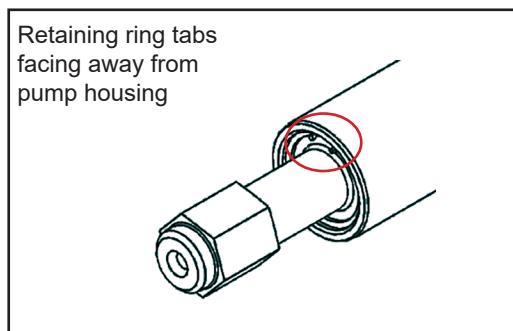

**Figure 7-9 - Retaining Ring Position**

THIS PAGE INTENTIONALLY LEFT BLANK

## Chapter 8 - Fits and Clearances

### 8.1 Torque Values

A. Torque values that are required during overhaul and repair of 500F Series fuel pumps are specified in Table 8-1.

Item Number	Part Number	Description/Location	In-Lb	N-m
9	NAS1352C3H20	Socket Head Cap Screw/ Relief Valve Cover	23-25	2.59-2.82
16	095F-0003	Jam Nut	25-30	2.82-3.39
19	090F-0003	Plug	30-40	3.39-4.52
26	AS5169D04L	Port Plug	100-110	11.30-12.43
30	090F-0001	Set Screw/Fuel Pump Housing	10-12	1.13-1.35

**Table 8-1 - Torque Values**

THIS PAGE INTENTIONALLY LEFT BLANK

## Chapter 9 - Test and Calibration

### 9.1 General

- A. After overhaul or repair of the fuel pump, the unit must be tested and adjusted.
- B. The fuel pump unit must be calibrated on a flow bench to verify that it is capable of operating within the limits specified in Table 9-1 before it can be used on an aircraft engine.
- C. Refer to Figure 9-1 for an example of the type of flow bench that should be used for testing and calibration purposes.
- D. Final adjustments and functional testing provide an accurate means of checking the ability of a pump to perform under simulated operating conditions.
- E. Stoddard solvent is satisfactory for fuel pump calibration.
  - (1) Flow bench test fluid should conform to the following specifications:
    - (a) Specific gravity, 75 °F (23.9 °C) ..... 0.765-0.775
    - (b) Viscosity, Centistokes 70 °F (21.1 °C) ..... 0.740-0.770
  - (2) Maintain test fluid temperatures between 60°F (15.6 °C) and 90 °F (32.2 °C) while testing a fuel pump unit.

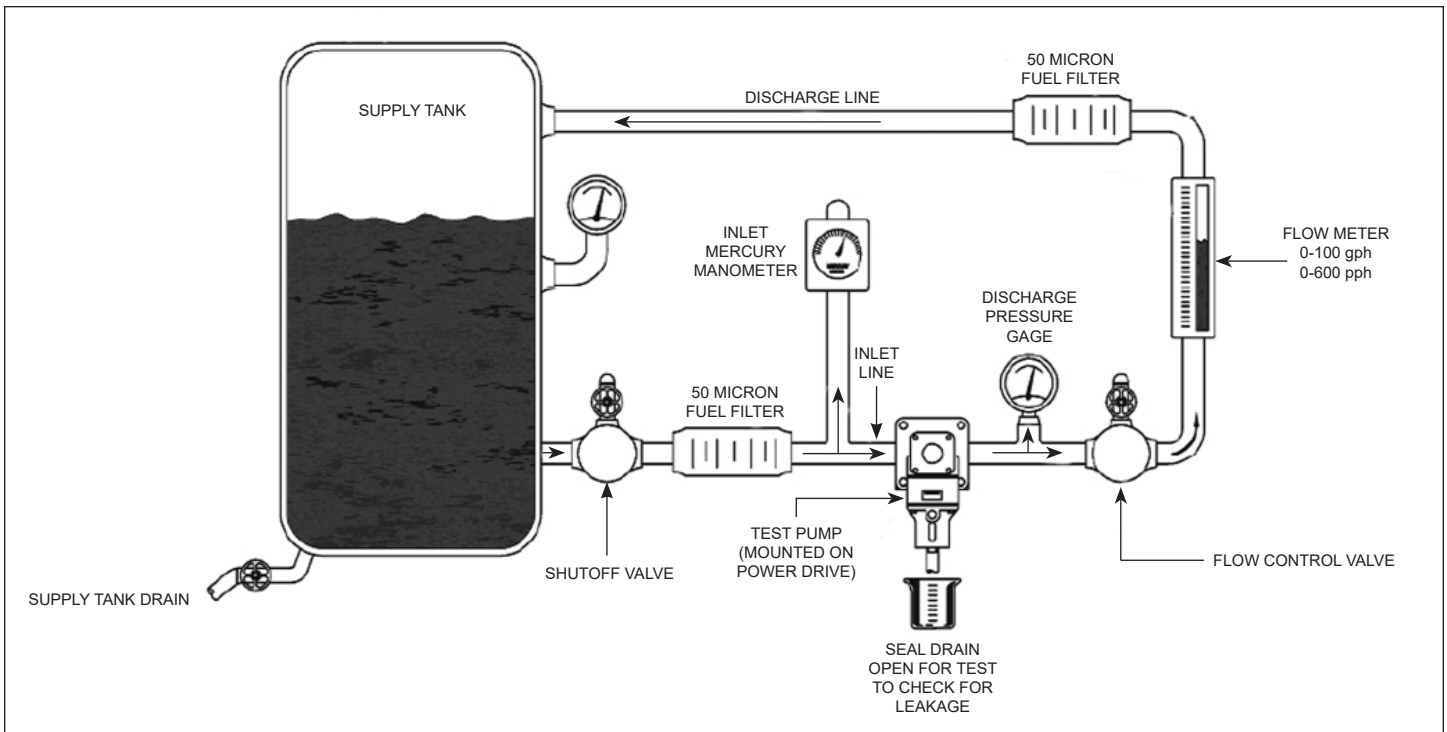

Figure 9-1 - Flow Bench Schematic

Model No.	Application	Direction of Rotation	Inlet Pressure (psia)	Speed (RPM)	Flow (pph)	Discharge Pressure (psig)	Notes
500F-0001	Piper PA-46-500TP	CW	14.2-14.7	3,665 ± 50	1,100 MIN	30 ± 2	-
				1,835 ± 50	550 MIN	24 MIN	-
500F-0002	Piper PA-46-600TP	CW	14.2-14.7	3,250 ± 50	1,300 MIN	28 ± 2	Post Test Setting
				1,625 ± 50	575 ± 5	24 MIN	-
500F-0004	Air Tractor AT-402, 402A, 402B, 502B, 503A, 504	CW	14.2-14.7	3,900 ± 50	820 MIN	18-22	Post Test Setting
				2,500 ± 50	330 MIN	18 MIN	-

**Table 9-1 - Relief Valve Settings**

## 9.2 Functional Testing and Calibration

### A. Leakage Test

- (1) Connect a regulated, oil free compressed air source to the inlet fitting of the fuel pump. Air pressure should be at zero to start.
- (2) Cap or plug the outlet fitting of the fuel pump.
- (3) Apply positive air pressure and fully submerge the fuel pump assembly into a container of Stoddard solvent.
- (4) Slowly increase air pressure to 60 psi and allow to remain pressurized for one or two minutes.
- (5) Look for any sign of leakage as evidenced by escaping air bubbles.
  - (a) If no bubbles are seen but air pressure declines over time, check the air source and test again.
  - (b) If any leakage is found, disassemble the fuel pump and repair as necessary.
- (6) Reduce supply air pressure at the source, bleed pressure from the pump, and remove the fuel pump from the solvent.
- (7) Disconnect the air source from the inlet port.
- (8) Remove the cap or plug from the outlet fitting of the fuel pump and put protective plastic caps on or in all of the open ports.
- (9) Use low pressure shop air to dry the solvent from the pump. (30 to 60 psi).

### B. Setting the Relief Valve

- (1) Refer to Table 9-1 for the applicable test parameters for each fuel pump model.
- (2) Loosen the jam-nut (16) and turn the relief valve adjusting screw (17) inward (CW) to increase pump discharge pressure or outward (CCW) to decrease discharge pressure.
- (3) Visually inspect for leaks throughout the functional test and calibration process. All leaks must be corrected.

- (4) After the pump has been satisfactorily adjusted, torque the jam-nut (16) in accordance with Table 8-1 in the Fits and Clearances section while holding the adjusting screw (17) stationary with an appropriate tool to prevent changing the adjustment setting.

**NOTE:** During testing, if the inlet pressure drops below 10 psig:

- (a) Remove the relief valve housing (14) and inspect the gasket (21).
- (b) If gasket has been pulled into inlet port on the valve housing, replace the gasket.
- (c) Reassemble and retest the pump beginning at section A.(2).

### 9.3 Final Inspection

- A. Using 0.032 (0.81 mm) safety wire, safety wire the jam-nut (16) to the hole in the relief valve cover (15) in accordance with industry accepted standards and practices for this procedure. Use of the HET P/N RX-1961 safety cable is also permitted. Refer to Figure 9-2.

**NOTE:** Refer to the IPL chapter for index numbers related to this section.



**Figure 9-2 - Jam Nut Safetying**

- B. Using 0.032 (0.81 mm) safety wire, safety wire the relief valve cover cap screws (9) in accordance with industry accepted standards and practices for this procedure. Use of the HET P/N RX-1961 safety cable is also permitted. Refer to Figure 9-3.



**Figure 9-3 - Cap Screw Safetying**

- C. Using 0.032 (0.81 mm) safety wire, safety wire the screw (30) to the fuel pump housing (1) in accordance with industry accepted standards and practices for this procedure. Use of the HET P/N RX-1961 safety cable is also permitted. Refer to Figure 9-4.

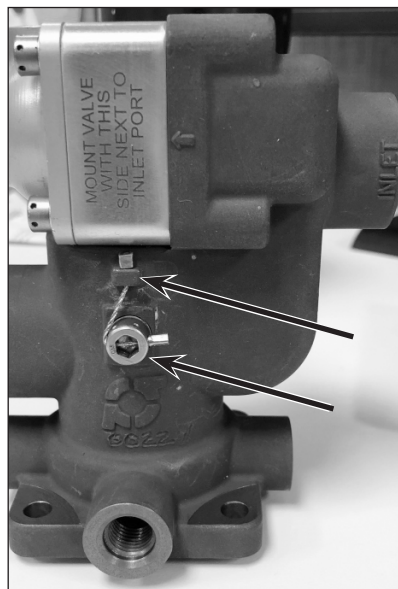

**Figure 9-4 - Screw Safetying**

---

## Chapter 10 - Special Tools, Fixtures, and Equipment

### 10.1 Minimum Facility and Tooling Requirements

#### A. Tooling

- (1) Some of the service operations described in this overhaul and maintenance manual require the use of specialty tools designed for this purpose.
- (2) These specialty tools or equivalent tools should be used as recommended.
- (3) Hartzell Engine Tech LLC assumes no responsibility for any person or organization using a service procedure or tool not specifically recommended by HET.

### 10.2 Special Tools and Fixtures

#### A. Special Tools

- (1) P/N 101F-0001 - Guide tool for rotor installations.
- (2) P/N 101F-0002 - Seal installation and removal tool.
  - (a) Tools are procurable through Hartzell Engine Tech LLC, 2900 Selma Highway, Montgomery, AL 36108, USA, or may be reproduced using the dimensional drawings shown in Figures 10-1 and Figure 10-2.

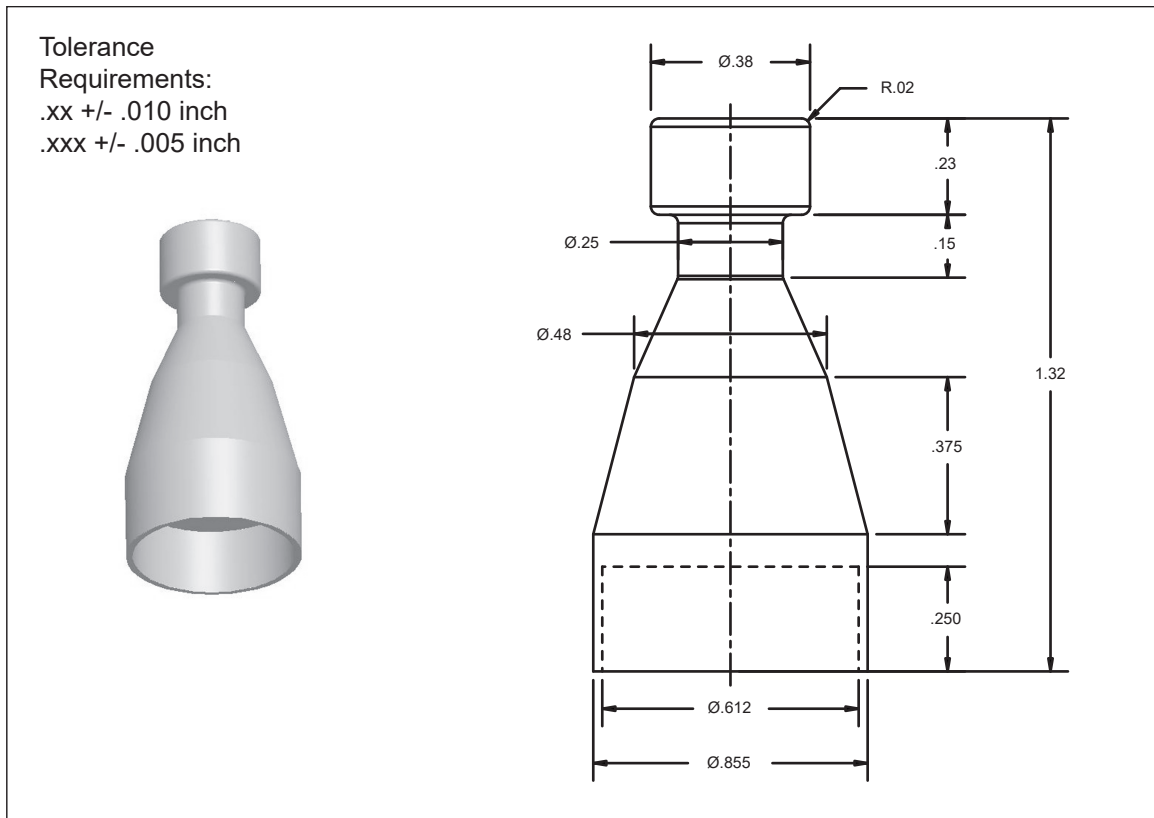
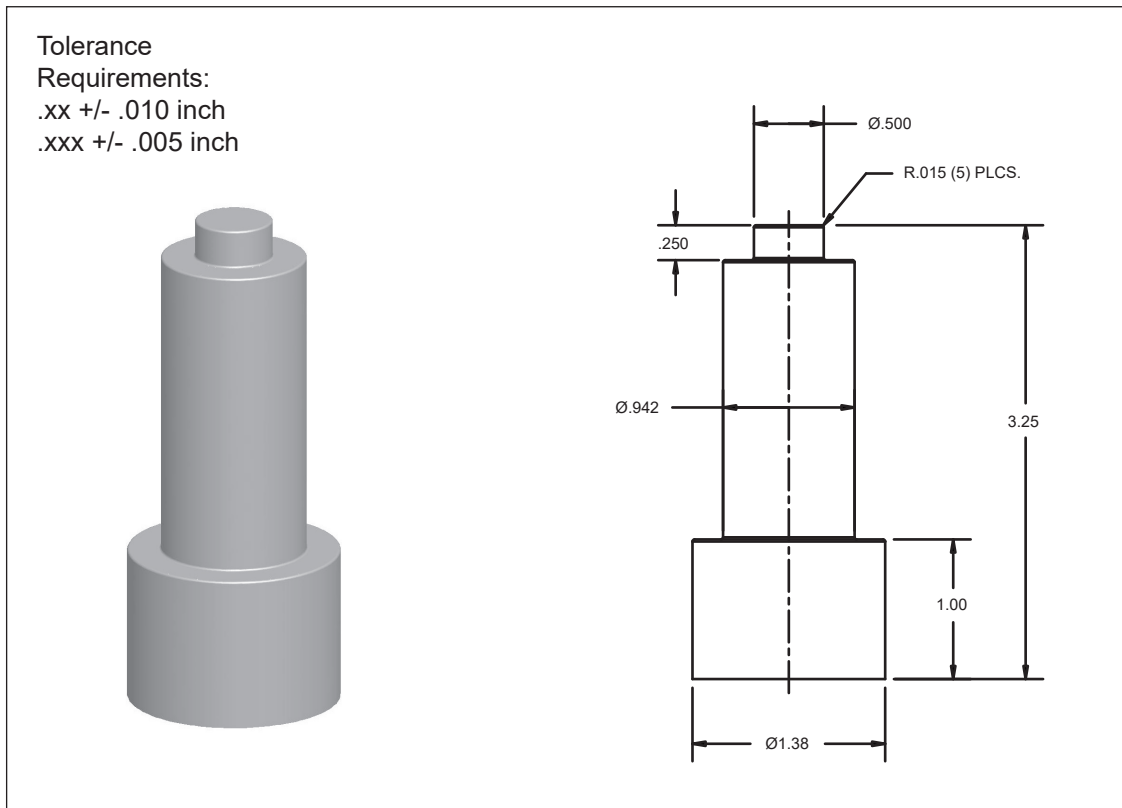

Figure 10-1 - Dimensions for Tool P/N 101F-0001  
Seal Guide



**Figure 10-2 - Dimensions for Tool P/N 101F-0002  
Seal Installation and Removal Tool**

THIS PAGE INTENTIONALLY LEFT BLANK

## Chapter 11 - Illustrated Parts List

### 11.1 Introduction

#### A. General

- (1) This Illustrated Parts List (IPL) contains all of the current configurations for the specified fuel pumps manufactured by Hartzell Engine Technologies LLC (HET) and supersedes any data that may have previously been supplied for part and assembly information. The parts lists contained within the IPL are to be used for verifying the configuration of fuel pump models and ordering parts.

**CAUTION:** FIGURES IN THE ILLUSTRATED PARTS LIST ARE TO BE USED FOR IDENTIFYING PARTS AND SHOULD NOT BE USED AS A MAINTENANCE REFERENCE FOR ASSEMBLY.

- (2) Figures and item numbers are for reference only. The figures provide general views of parts. Illustrated parts may not exactly reflect parts contained in some fuel pump assemblies.

### 11.2 Illustrated Parts List

#### A. Detailed Parts List

The Detailed Parts List consists of the Figure/Item Number, Part Number, Description, and Units Per Assembly. Space is reserved for the Airline Stock Number. The following is an explanation of each column:

- (1) Figure/Item Number
  - (a) Figure Number refers to the illustration where items appear.
  - (b) Item numbers are assigned in numerical order by part number. Item numbers in the Illustrated Parts List are referenced throughout the text of this manual. Items listed but not illustrated are identified by a dash in place of an item number.
  - (c) Alpha variants are used to add additional items. There are three reasons for the use of alpha variants:
    - 1) A part may have an alternate, or may be superseded, replaced, or obsoleted by another part.
- (2) Part Number
  - (a) Use the Hartzell Engine Technologies LLC (HET) part number when ordering a part from HET or a HET approved distributor.
- (3) Description
  - (a) The description column identifies the item. The relationship of parts to assembly are indicated by the use of indentations. This column may also contain vendor CAGE codes, as applicable. Information regarding part alternative, supersedure, replacement, or obsolescence may also be found in this column. Refer to Revisions, below, for further information regarding alternate, superseded, replaced, or obsoleted parts.

(4) FP P/N - QTY

- (a) The FP P/N section contains next higher assemblies or subassemblies; used in place of effectivity codes.
- (b) Designates the total quantity of an item required for the next higher assembly or subassembly.

B. Revisions

(1) Alternate

- (a) Alternate parts are identified by the term "ALTERNATE" in the Description column. Alternate items are considered acceptable for continued use and existing stock of parts may be used for maintenance and/or repair. The part numbers may be used interchangeably when ordering/stocking new parts.

(2) Supersedure

- (a) Part changes are identified by the terms "SUPERSEDES ITEM \_\_\_\_\_" or "SUPERSEDED BY ITEM \_\_\_\_\_" in the Description column. Superseded items are considered acceptable for continued use and existing stock of superseded parts may be used for maintenance and/or repair. Once the superseding part has been incorporated/installed into an assembly, the original superseded part may no longer be used. Superseded parts may no longer be available, and the new part number must be used when ordering/stocking new parts.

(3) Replacement

- (a) Part changes identified by the terms "REPLACES ITEM \_\_\_\_\_" or "REPLACED BY ITEM \_\_\_\_\_" in the Description column are considered acceptable for continued use, but must be replaced with a part with the new part number at overhaul. Existing stock of replaced parts may not be used for maintenance and/or repair of affected assemblies. Replaced parts may no longer be available, and the new part number must be used when ordering/stocking new parts.

(4) Obsolescence

- (a) Obsolete parts are identified by "OBS" in the QTY column. Obsolete parts are considered unacceptable for continued use.

(5) Service Documents and Airworthiness Directives

- (a) In the event of modification or rework of an existing part, the supersedure, replacement, or obsolescence of a part, or the addition of parts installed by a Alert Service Bulletin (ASB), Service Bulletin (SB), or Service Letter (SL), the ASB, SB, or SL number will appear in the Description column as "ASB \_\_\_\_\_", "SB \_\_\_\_\_", or "SL \_\_\_\_\_" after the description.
- (b) When a ASB or SB has a relationship to an Airworthiness Directive (AD), the AD will be shown in parentheses after the ASB or SB number as ASB \_\_\_\_\_ (AD \_\_\_\_\_) or SB \_\_\_\_\_ (AD \_\_\_\_\_).

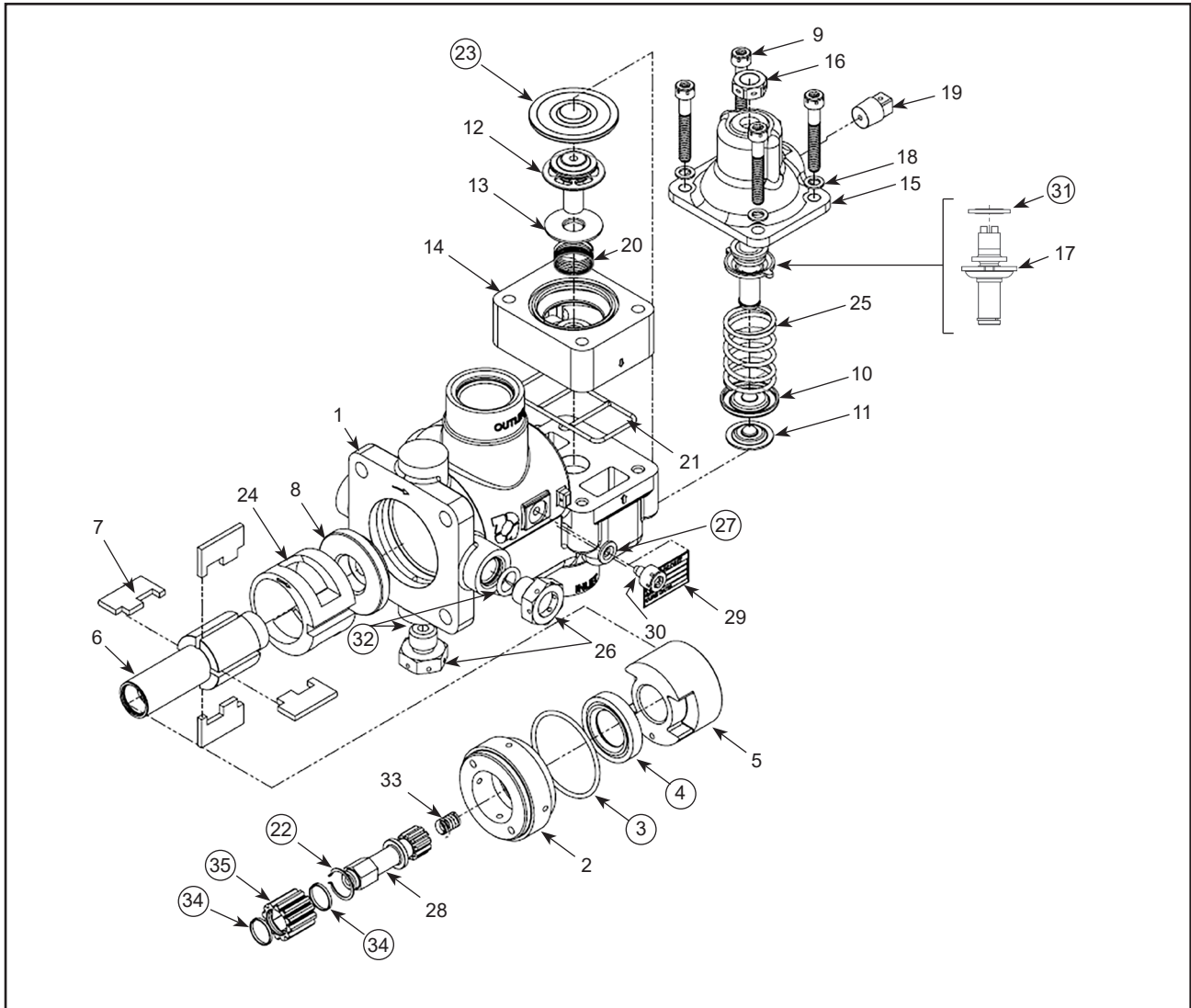

Figure 11-1 - 500F-0001, 500F-0002, & 500F-0004 Fuel Pump



Index No.	Part Number	Description	FP P/N - QTY					
			500F-0001	500F-0002	500F-0004			
1	030F-0016	Housing, Fuel Pump	1	1	1			
2	030F-0017	Locknut	1	1	1			
③	070F-0004	Packing	1	1	1			
④	070F-0011	Seal	1	1	1			
5	075F-0008	Bearing	1		1			
6	025F-0016	Rotor	1		1			
	025F-0012	Rotor		1				
7	055F-0008	Blade, Pump	4					
	055F-0005	Blade, Pump		4				
	055F-0007	Blade, Pump			4			
8	075F-0001	Bearing	1	1	1			
9	NAS1352C3H20	Screw, Cap	4	4	4			
10	100F-0003	Seat, Spring	1	1	1			
11	100F-0004	Plate, Diaphragm	1	1	1			
12	100F-0009	Valve, Poppet Relief	1	1	1			
13	100F-0006	Valve, Bypass	1	1	1			
14	020F-0005	Housing, Valve	1	1	1			
15	050F-0008	Cover, Valve	1	1	1			
16	095F-0003	Nut, Jam	1	1	1			
17	090F-5001	Screw, Adjusting Assembly	1	1	1			
18	065F-0003	Washer	1	1	1			
19	090F-0003	Plug	1	1	1			
20	080F-0003	Spring	1	1	1			
21	060F-0003	Gasket, Valve	1	1	1			
②②	025F-0015	Retaining Ring	1	1	1			
②③	063F-0001	Diaphragm	1	1	1			
24	075F-0014	Liner	1					
	075F-0010	Liner		1				
	075F-0013	Liner			1			
25	080F-0013	Spring	1	1	1			
26	AS5169D04L	Plug, Port	2	2	2			
②⑦	NAS1523-08E	Packing w/ Retainer	1	1	1			
○ Circed item numbers are required replacement items at overhaul								
* Refer to Chapter 1 for Data Tag criteria								

Table 11-1 - IPL (Cont'd)



THIS PAGE INTENTIONALLY LEFT BLANK